

Worth Data
R/F Terminal
Owner's Guide

10/03

Table of Contents

Chapter 1	Installation	1-1
	Components	1-1
	Installation Summary	1-2
	Connecting the Base Station to a serial port.....	1-2
	R/F Terminal Operation	1-4
	Battery Functions	1-4
	R/F Terminal Menu Functions	1-7
	Installing the R/F Terminal Utilities Software	1-9
Chapter 2	RF System Setup	2-1
	RF Terminal Setup	2-1
	RF Terminal Default Settings	2-1
	Using the bar code RF Terminal Setup Menu	2-2
	Using the keypad to setup the RF Terminal	2-3
	RF Terminal Setup Parameters.....	2-5
	Base Station Setup.....	2-27
	Base Station Setup Parameters	2-29
Chapter 3	Operational Theory	3-1
	How the Two-Way RF System works	3-1
	How the One-Way RF System works.....	3-4
	How Site Testing works	3-5
Chapter 4	Performance Issues	4-1
	Evaluating your area of planned operation.....	4-1
	Performing a Site Test.....	4-2
	Relay Stations.....	4-4
	Dealing with radio traffic contention.....	4-7
Chapter 5	Before you begin programming	5-1
	Failure Planning	5-2
Chapter 6	Programming for the RF Terminal	6-1
	Low Level ASCII sequences	6-1
	Low Level ASCII sequences with Windows DLL	6-12
	PromptCOM ActiveX Controls.....	6-12
	TCP/IP ActiveX Controls.....	6-21
Chapter 7	Voice Message Operations	7-1
	Why Use Voice Messages and Prompts?	7-1
	RF Terminal's Voice Message Mapping.....	7-2
	Programming Voice Messages	7-3
Chapter 8	Troubleshooting	8-1

Appendices

A	Frequency and Jumper Changes	A-1
B	Adding Relays	B-1
C	R/F Serial Pin-outs	C-1
D	Firmware Upgrades.....	D-1
E	Code 39 Specifications	E-1
F	Code 93 Specifications	F-1
G	Codabar Specifications	G-1
H	Code 128 Specifications	H-1
I	Interleaved 2 of 5 Code Specifications	I-1
J	UPC / EAN Specifications.....	J-1
K	MSI/Plessey Specifications	K-1
L	Piggyback Laser Installation.....	L-1
M	How to scan a bar code	M-1
N	Using the Scan Stand	N-1
O	Optional Features.....	O-1
P	ASCII Code Equivalent Table	P-1
	Index	1

Chapter 1

Installation

Components

The components in your R/F Terminal system will vary according to the configuration of your system. Your R/F Terminal shipment should contain at least:

- **An R/F Terminal T7x or LT7x** (unit includes keypad and display). If the R/F Terminal is an LT7x model, it will have an integrated laser scanner built-in to the body of the terminal.
- **An optional Scanner** – Laser, Wand or CCD that plugs into the scanner port of the R/F Terminal. You have a built-in laser scanner if you ordered the LT7x model. (LT means Laser Terminal)
- **A Shoulder Strap and Rubber Boot** – which if used, will minimize the damage from accidental drops in usage. (The shoulder strap has to be installed with a screw driver per the included instructions)
- **A R/F Terminal Setup Menu**- this is an 8.5” x 11” laminated sheet consisting of bar codes used to configure the R/F Terminal.
- **Utilities CD ROM** – demo programs, DLL, and firmware loader program!

If *Base Stations* or *Relay Stations* were ordered with your system, you should receive at least:

- **A Base Station (B5x) and/or Relay Station (R5x)** including a 5v power adapter for each.
- **A Serial Cable (F34 or F36)** if a *Base Station*.
- **RS422 Y Cables (F44)** if using multiple *Relay Stations*.
- **A Test Relay Cable** – if a Relay was ordered. This is a short cable just for testing. Relay cables are much longer and are supplied by the user, (use CAT 5 or Belden **1227A1** wire.)

Keep the shipping box for the R/F Terminal in the event it is necessary to return equipment for repair later.

Installation Sequence

1. **Start with one Terminal and Base Station.** Get everything working with the single terminal and base and then add other terminals, being certain that all terminals have unique *Terminal IDs*. After all terminals are working, add the first relay, remembering to change each terminal's setup to *Relay=Yes* before testing. Then add remaining relays, remembering to: 1) assign *Relay IDs*, and 2) set the jumpers of each relay to *terminated* or *not terminated* properly.
2. All equipment is shipped with the default setting of Frequency 0. Unless you have other Terminal/Base configurations already operating on that frequency, you probably don't need to change the frequency.
3. Remember, Relays and Bases are not the same product. They look the same, but they have different firmware, attach differently, different jumper settings, and different product labels. Relays and Bases can be converted in the field with new firmware EPROM and jumper changes. (Base Stations and relays require a 5v power supply from Worth Data. If you use a different power supply, it will probably burn up the Base or Relay Station.)
4. Without attaching the Base Station to the computer, and with only the power supply plugged in the base, you can perform a site test to be sure you have adequate coverage and the radios are working perfectly. (See *Chapter 4*).
5. Now connect the Base Station to the computer's serial port. Be sure to turn OFF all handshaking on the COM port used; in Windows, go to Start Menu, Settings, System, Device Manager, Ports (COM and LPT). Now run one of the RF Terminal demo programs found on the *Utilities CD-ROM*.
6. Now run one of the demo programs to validate that everything is working. If you have problems, refer to the **Trouble Shooting Section**.

Connecting the Base Station to a serial port

How it works...

The R/F Terminal transmits data to the Base station, which in turn transmits the data *to* the host serial port. The computer software reads the data coming through the serial port and processes the information accordingly. When the computer software running on the host has a task for the terminal, it transmits data *out* to the serial port, which then passes this data on to the Base station.

The Base station then broadcasts the message to the terminal, causing the terminal to display the message to the user.

The Base station is not machine-sensitive (it needs a standard RS-232 serial port) nor is it operating system dependent (you just need to be able to read and write to the serial port as a separate device).

Connecting the Base station...

If you specified a 25 pin cable (part #F34) or a 9 pin cable (part #F36) when you ordered your Base station, simply plug the RJ45 end of that cable into the **COMPUTER** port on the Base station, and the 25 or 9 pin end into your computer's serial port. If you are *not* connecting to a PC, see **Appendix C** for cable and serial pin-outs.

If your extension cable is over 80 feet long and you are running Windows, open up the DB9 or DB25 connector on the base station side and cut the unused pins (see **Appendix C.**).

For an extension cable, you can use existing network cabling already in existence, but you must be certain that the Transmit and Receive data lines are not in the same twisted pair.

If you are using an extension cable and are having problems, test the cable by:

1. Connecting the Base station *without* using the extension cable. Simply plug in the F34 or F36 cable that came with the Base.
2. If the Base works with *only* the F34 or F36 cable in place, add in the extension cable **without changing the physical location of the Base station.** If the extension cable appears to be the culprit, check to be sure that Transmit lines are connected to Receive lines.

Configuring the Base station...

After connecting the Base station to your serial port, you need to configure the serial settings on the Base station to match those required by your software. We recommend using the default settings when at all possible. The default settings are:

- 9600 baud
- No parity
- 8 data bits
- 1 stop bit
- "None" protocol setting

If you have to change any or all of these settings, see **Chapter 2** for details on configuring the Base station using the R/F Terminal keypad.

Base station frequency...

To determine what frequency your Base station is set to, plug in the power supply and watch the LED light on the front of the Base station. The LED will blink “the frequency + 3” times.

For example, the default frequency is 0. On power up, the LED on a Base station set to frequency 0 would blink 3 times. A Base station set to frequency 5 would blink 8 times.

If this is the only Base station operating, leave the frequency at 0. If you have other Base stations in the area and need to change the frequency, see **Appendix A; Frequency and Jumper Changes** for details on how to open the Base station and set the rotary switch inside to the desired frequency.

R/F Terminal Operation

Using the RF Terminal keypad...



The R/F Terminal is turned on by pressing the green ON/OFF button located in the upper left-hand corner of the R/F Terminal keypad.

The R/F Terminal has a *Shut Down Time* feature that allows you to determine the length of time the R/F Terminal must be inactive before automatically shutting down to conserve battery power. When the R/F Terminal shuts down, simply press the ON/OFF button to resume operation.

The keypad is custom designed for the R/F Terminal operations. It has numeric and control keys in the non-shifted state, and alpha characters in its shifted state. You can readily determine if the SHIFT is on by the cursor on the display. When SHIFT is on, the cursor is a large black rectangle. When SHIFT is off, the cursor is a narrow underline character. For all prompts which ask for a YES or NO response, the ENTER key, is the YES reply, and the -(minus) key is the NO reply. As you key data, you will see each character displayed on the screen. If you make a mistake, you can delete the last character by pressing the DELETE key, or you can clear all characters displayed on the screen by pressing the CLEAR key.

Battery Functions

Three AA batteries provide the main power for the scanner, display and electrical circuitry. Either **alkaline** (including Alkaline rechargeables), **Nickel Metal Hydride** rechargeable batteries or **NiCad** rechargeables may be used, (Nickel Metal Hydride, **NiMH**, batteries are preferred). If you decide to use NiCad or NiMH batteries, be sure change the Terminals Setup in *Speaker/Batteries* to rechargeable batteries; otherwise, the terminal will not know when to shut down without causing problem. **NiCad** and **NiMH** batteries don't have the same level of reserve power as alkalines, so the Terminal will

attempt to continue operation beyond the capability of the batteries if the Setup is left at the default alkaline setting.

Alkaline batteries (including alkaline rechargeables) should provide approximately 14 hours of continuous operation with 8 transactions per minute average. **NiCad** rechargeable batteries will give approximately 40% less operational time than alkalines.

Rechargeable Batteries

If you want to use rechargeable batteries, you can use a fast external 3rd party charger, you can use slower trickle recharging circuitry that allows you to recharge the batteries while installed in the R/F Terminal. To use the recharging circuitry on the T71/LT71 terminals, you must change a jumper inside the R/F Terminal itself, (see **Appendix A, Hardware Changes on the RF Terminal**). Recharging circuitry is standard on the European terminals – there are no jumper changes required.

To recharge batteries in a RF Terminal, simply plug in an optional additional charge Worth Data 5v Power Adapter. For best results, use only **NiMH** rechargeable batteries. NiMH Rechargeable Batteries are available from Worth Data and can be ordered as part number L01 for \$10.00 for a set of 3. The internal trickle charge takes 8-10 hours. Inexpensive, external chargers can be purchased which recharge batteries in 2-3 hours.

You can safely use alkaline batteries in a terminal set for recharging, **providing** you don't plug a power supply into the terminal. ***Recharging Alkaline batteries may cause the batteries to explode and leak battery acid throughout the RF Terminal.*** Battery acid damage is not covered by the Worth Data warranty because it not deemed to be “normal use”.

IMPORTANT! If you decide to use **NiMH** or **NiCad** batteries, with the internal charging or an external charger, be sure to change the ***Speaker/Battery*** setting to “rechargeable” or your terminal will start exhibiting very strange behavior as the batteries run down.

If you are using alkaline batteries (either *regular* or *rechargeables*) and have selected the **NiCad/Rechargeables** setting in the ***Speaker/Battery*** setup parameter (See **Chapter 2; RF System Setup**), the RF Terminal will generate the following error message:

**Warning Alkaline
Batteries Detected
Nicads Are Specified
Do Not Recharge**

Battery Life Indicator

The R/F Terminal detects low AA batteries and displays the following message:

LOW BATTERIES
Finish, Sign Off
Change Batteries
Hit Any Key_

At this point you have approximately 2 minutes of operational time to finish your transaction (or note where you are leaving off if in the middle of a transaction) and sign off. After 2 minutes, the R/F Terminal will display:

CHANGE BATTERIES
UNIT SHUT DOWN_

This message will display for 20 seconds before the R/F Terminal signs off from the host (if signed on) and then shuts itself down. If you turn it back on without changing batteries, you may experience constant beeping, intermittent scanning, and very irritating symptoms that look like equipment failure.

Once you remove the batteries, you have 5 minutes to change them before you lose the date and time in the Real-Time Clock.

The R/F Terminal also has a battery life indicator that can be accessed while operating in ONE-WAY or TWO-WAY mode or while in the MENU. To display the remaining battery life of the AA batteries (as well as the date and time) press the STATUS key:

mm/dd/yy hh:mm

AAxBAT■■■■■■■■■■■-zz%

x=a when Alkaline batteries are specified in Speaker/Battery setup

x=n when NiMH or NiCad batteries specified in Speaker/Battery setup

zz=percent in numbers i.e. 99, 10, 05

Press the STATUS key again to resume processing.

To change the AA batteries:

1. Turn **OFF** the R/F Terminal.
2. Remove the battery holder door on the back of the R/F Terminal by pressing down on the grooved portion of the door and pushing outward.
3. Remove the old batteries and insert the new ones, making sure to orient the batteries according to the diagram inside the battery holder. The positive (+) end of the battery should be facing down toward the bottom of the R/F Terminal.

4. If using rechargeable batteries, make sure that rechargeables are specified. See the previous page to quickly determine the setting using the *Status key*.
5. Replace the battery door and turn the reader on using the ON/OFF switch.
6. Sign ON and resume your application.

R/F Terminal Menu Functions

There are four modes of operation for the R/F Terminal:

SIGN ON	<i>Signs R/F Terminal on for two-way communication with host.</i>
SETUP MODE	<i>Accesses Setup parameters for Terminal and Base.</i>
ONE-WAY	<i>Allows “dumb” data entry to computer. No prompts from host computer</i>
SITE TESTING	<i>Allows user to test range and evaluate site to determine best position for Base. Also the acid test for suspected radio failure.</i>

Upon power-up, the R/F Terminal displays the following opening screen:

```

R/F TERMINAL S9nnn
TERM ID: 0 6/6
XXX FREQUENCY: 0 Z
HIT ANY KEY

```

*(The opening screen can be bypassed upon power up. See **Chapter 2** for details)*

- The first line on the screen, **R/F TERMINAL S9nnn**, gives the firmware revision number.
- **TERM ID: 0** refers to the current Terminal ID. The default setting is **0**. If operating in a multi-R/F Terminal system, each Terminal must have a unique ID. The second part of this line identifies the display lines. Possibilities are **4/4** (4 line terminal operating in 4 line mode), **6/4** (6 line terminal operating in 4 line mode, and **6/6** (6 line terminal operating in 6 line mode).
- Line 3 refers to the frequency currently used by the R/F Terminal. **XXX FREQUENCY: 0** refers to a Terminal set to frequency **0**. **XXX** corresponds to the country the frequency corresponds to. A Terminal using the USA /Canada/Mexico frequencies would read **USA FREQUENCY:0**. If a **Z** also appears on this line to the right,

the terminal is capable of supporting the *Zebra Cameo* and *Encore* portable printers.

To move on to the first menu item, press any key on the R/F Terminal keypad. The display now reads:

**SIGN ON?
KEY [YES/NO]?_**

- Press the **YES** key to **SIGN ON** to a two-way communication host computer program through the Base station.
- Press **NO** to move on to the next menu item:

**SETUP MODE?
KEY [YES/NO]?_**

- Pressing **YES** prompts for a password to enter the *Setup Mode* for the R/F Terminal or Base station.
- Press **NO** to move on to:

**ONE-WAY?
KEY [YES/NO]?_**

- Press **YES** to enter ONE-WAY mode. ONE-WAY mode allows the R/F Terminal to transmit data to the host computer without prompting from the host computer program – we call this “dumb” data entry. ONE-WAY mode is also useful for demos, as it does not require any interaction from the host computer.
- Press **NO** to go to:

**SITE TESTING?
KEY [YES/NO]?_**

- Press **YES** to enter SITE TESTING. SITE TESTING is an excellent way to assess your R/F communication in any area. It can help you determine the best place to locate your Base station for maximum R/F performance as well as troubleshoot problems that may relate to range or interference.
- Press **NO** to loop back to the SIGN ON? prompt.

You can back-out of any mode or prompt by pressing the F1 key. For example, if you press YES at the SETUP MODE? prompt but really meant to press NO, press the F1 key to take you back to the menu. The F1 key on the R/F Terminal keypad works like the ESC key on the PC – it will usually get you out and back to the previous step. You can use the F1 key to exit and SIGN OUT when using a Two-Way communication program running on the host computer.

The entire mode menu can be skipped (see **Chapter 2; RF System Setup**), causing the R/F Terminal to automatically SIGN-ON or go to ONE-WAY mode on power up.

Installing the R/F Terminal Utilities Software

The R/F Terminal system ships with a CDROM of programs for use with the R/F Terminal and Base station. The CDROM contains programs for the TriCoder and the RF Terminal. Click on the RF Terminal button.

Next you have the choice of installing the following:

Windows Demo Programs and RF DLL Programmers Library

Demo Programs in VB, Access, and Delphi
16 bit and 32 bit DLLs
VB DLL-based Encore printer demo program

ActiveX Tools

Serial Interface (*includes Excel and VB demos*)
TCP/IP (*includes VB/Access and Delphi demos*)

Windows RF Terminal Firmware Loader Program

DOS/BASIC source demo programs (requires GWBasic or QBasic)

Click on the set of programs you wish to install.

To install any of the programs found on the Utilities CD, simply insert the CD into your CDROM drive. The install program should start automatically. If it does not, simply run the SETUP.EXE program found on the CD.

Running the demo programs...

The demo programs are all programs provided to help you test your R/F Terminal with a two-way communication program.

Using the Windows Terminal Loader Utility

The R/F Terminal Loader program is a Windows application that allows you to download new R/F Terminal firmware from Worth Data into your R/F Terminal. New firmware can be obtained on diskette directly from Worth Data or downloaded via the Web at:

<http://www.barcodehq.com/download.html>

Installing the Windows Terminal Loader Utility

This program is for Windows 95, 98, NT, 2000, ME and XP :

1. Insert the CDROM into your CD drive. The "Hardware Utilities Installation" program should start automatically. If it does not, double click on the SETUP.EXE program on the CD in Windows Explorer.
2. Click on the RF Terminal button to select the type of hardware.
3. Click on the "Install RF Loader" button.
4. Follow the installation instructions on the screen.

Setup installs three programs and creates a program group for them:

R/F TERMINAL EPROM LOADER HELP
R/F TERMINAL EPROM LOADER
UNINSTALL

See **Appendix D**; *Firmware Upgrades* for details on how to use the EPROM Loader programs (Windows).

Chapter 2

RF System Setup

RF Terminal Setup

The RF Terminal itself can be configured using the Terminal keypad or by using the bar coded Setup Menu. Even if you configure the RF Terminal using the keypad, you may need the bar coded Setup Menu to use as a reference. Most users do not need to change anything in the setup. The most commonly changed setup parameters are the Terminal ID (especially if you have more than 1 terminal) and the Frequency (if you are adding an additional Base station). Some parameters are available only by bar code menu and others only by keypad:

Bar Code Menu Only	Keypad Only
Characters	Security Code
Reset	Frequency Bank
	Host Response Delay
	Relay Existence
	Arrow Keys Only
	Skip Opening Screens
	Display of Year
	LCD Display Mode
	LCD Backlight Display

If you are using the bar coded Setup Menu and are unfamiliar with scanning bar codes, see **Appendix M; How to scan a bar code** to learn proper scanning technique before you begin scanning the bar codes on the Setup Menu.

RF Terminal Default Settings

This is the default configuration of the RF Terminal as it is shipped from the factory. If you ever need to return the RF Terminal to these default settings, use the bar coded Setup Menu and scan the following bar codes in this sequence:

- START SETUP
- RESET
- END SETUP

Default RF Terminal Configuration

Parameter	Default Setting	Parameter	Default Setting
Radio Terminal ID	0	MSI Code	Disabled
RF Frequency	0		check digit not transmitted
Relay Exist?	No		Plessey Code disabled
Code 39	Enabled		Label Code5 disabled
	Accumulate Mode ON	Code 93	Disabled
	stop/start chs not xmit		Full ASCII disabled
	check digit disabled	Date Format	mm-dd-yy (if US version)
	Caps lock OFF		dd-mm-yy (if other)
2 of 5 Code	Disabled	Beep Tone	medium
	1 2 of 5 Code disabled	Speaker Operations	Speaker on
	6 digit code length		Alkaline batteries used
	check digit disabled	Preamble	none
	Enabled	Postamble	none
UPC/ EAN	UPC supps disabled	Baud Rate	9600
	UPC-A NSC & check digit transmitted	Parity	none
	EAN-13 country code & check digit transmitted	Data Bits	8
		UPC-E 1st char & check digit not transmitted	Stop Bits
	EAN-8 1st char & check digit not transmitted	Security Code	none
			Frequency Bank
Codabar	Disabled	Laser Options	none
	Start/Stop not transmitted	Shut Down Time	5 minutes
	CLSI format disabled	Voice Messages	303015
Code 11	Disabled	Arrow Keys Only	no
Code 128	Disabled	Characters	none reassigned
	EAN/UCC 128 disabled	Host Response Delay	none
		Display of year	2 digit
		Skip opening screens	no
		LCD Display Mode	0
		LCD Backlight Display	0

*All parameters are set back to their defaults when reset using the bar coded Setup Menu, even parameters that are changed by keypad only. Shaded items are keypad access only.

Using the bar code RF Terminal Setup Menu

To use the bar coded RF Terminal Setup Menu, scan these bar codes in this order:

- **Start Setup** - you should hear 2 beeps
- **Setup Parameter bar code** (i.e. "Beep Tone")-you should hear 2 beeps for each scan
- **Number bar code that corresponds to the appropriate setting** (i.e. "3" to change the Beep Tone to "high") - you should hear 2 beeps for each scan
- **End Setup**-you should hear 3 beeps after END SETUP.

More than one Setup Parameter can be changed before you scan END SETUP. For example, if you scanned START SETUP, then "Beep Tone", then 3, then "Speaker Operation", then 1, then END SETUP, this would change the beep tone to "high", and turn the speaker "off".

If you are using a Laser Scanner to setup the RF Terminal, the beam will often cover more than one bar code. Cover any adjacent bar codes before scanning, and then check the RF Terminal display to make sure the correct setting was entered.

Using the keypad to setup the RF Terminal

The RF Terminal can be setup via the Terminals' keypad by entering *Setup Mode* from the menu. Turn on the Terminal and press any key. You should see the SIGN ON? message:

**SIGN ON?
KEY [YES/NO]?_**

Press the NO key. The next prompt is the SETUP MODE? prompt:

**SETUP MODE?
KEY [YES/NO]?_**

Press the YES key. At this point, the terminal will ask for a password:

**SETUP MODE
PASSWORD?_**

Enter WDTRI on the keypad. The next item allows you to choose which item to configure:

**R/F Terminal----->1
R/F Base Setup--->2
Voice Operations->3**

Press 1 to enter the RF Terminal Setup. Now you are in the RF Terminal Setup Menu and can choose from the following options:

**RF Setup---0 Speaker--4
BarCodes--1 Other-----5
RS232-----2 Exit-----F1
Date/Time--3**

At this point, choose which group you want to configure. Most of the RF Terminal setup parameters are accessible from the keypad Setup Menu (there are only 2 that are available only from the bar code Setup Menu). Conversely, there are quite a few options that are available only from the keypad Setup. See the beginning of this chapter for a comparison of the two Setup Menus.

The groups in the keypad Setup Menu contain the following setup parameters:

Setup Group	Parameter	Setup Group	Parameter
RF Setup	RF Terminal ID	RS232	Baud Rate
0	RF Frequency	2	Protocol
	Relay Existence		Parity
	Security Code		Data Bits
	Frequency Bank		Stop Bits
	Skip opening screens		
	Host Response Delay	Date/Time	Set Time
		3	Set Date
Bar Codes	Code 3 of 9		Date Format
1	UPC/EAN		Display of Year
	Code 2 of 5/1 2 of 5		
	2 of 5 Length	Speaker	Speaker/Batteries
	Code 128	4	Beep Tone
	Codabar		
	MSI/ Plessey	Other	Shut Down Time
	Code 11	5	Preamble
	Code 93		Postamble
			Voice Messages
			Laser Options
			Arrow Keys Only
			LCD Display Mode
			LCD Backlight
			LCD Backlight Duration
			Arrow Keys Only

Once you have selected a group to edit, you will see each parameter displayed in the order listed above. Use the next section of this chapter as a reference for all RF Terminal Setup Parameters, whether they are configured using the keypad or the bar coded Setup Menu. Each parameter is followed by either a key symbol:



and the group you will find the parameter in, *RF Setup*

or a bar code symbol:



or both, depending on how the parameter can be configured.

RF Terminal Setup Parameters

Default settings are shown in **bold** type in this manual and are marked by a * on the bar code Setup Menu.

The RF Terminal will typically require no setup changes except, Terminal ID (if more than one terminal) and enabling bar codes to be read other than UPC or Code 39.

RF Terminal ID



RF
Setup

Default ID	0
Available ID's	0-9, A-F

- The default **Terminal ID** is always shipped as **0**. If you have more than one RF Terminal assigned to a Base Station, you must be sure that each RF Terminal has a unique **Terminal ID**, (otherwise you will have big troubles including false error messages). The **Terminal ID** is always displayed on the Start Up screen when you power up the terminal. There are sixteen **Terminal ID's** available - the numbers **0-9** and the letters **A-F**. To change the **Terminal ID**, enter one character either by scanning from the bar code Setup Menu or by pressing a key on the RF Terminal keypad. The frequency setting is displayed on the RF Terminal's opening screen.

RF Terminal Frequency



RF
Setup

Default Frequency	0
--------------------------	----------

- The default **Frequency** is always shipped as **0**. There are 16 frequencies on **Bank 0** that will accommodate just about everyone. By switching frequency banks, there are 80 frequencies available, but they are rarely used. The Frequency can be set to any of the 16 frequencies on any bank by entering the corresponding character (0-9, A-F) either by scanning the bar coded Setup Menu or by entering the character from the RF Terminal keypad.
- All Terminals, Base Stations and Relays in the same system must be set to the same frequency. The frequency is always displayed on the Start Up screen when you power up the Terminal. If you are using Relays, you are restricted to Bank 0 only. Site tests and Base Programming always take place on Bank 0.
- There are different frequencies available depending upon the country you are operating in. Each country has a different EPROM version and will display the version on power-up.

These are the frequencies available for each country:

USA / Canada / Mexico

There are 80 frequencies available for the US, Canada and Mexico. These frequencies display as "USA Frequency" on the screen upon power-up of the Terminal. The frequencies in MHz are:

Freq.	Bank 0	Bank 1	Bank 2	Bank 3	Bank 4
0	911.75	902.35	908.75	915.15	921.55
1	912.15	902.75	909.15	915.55	921.95
2	912.55	903.15	909.55	915.95	922.35
3	912.95	903.55	909.95	916.35	922.75
4	913.35	903.95	910.35	916.75	923.15
5	913.75	904.35	910.75	917.15	923.55
6	914.15	904.75	911.15	917.55	923.95
7	914.55	905.15	911.55	917.95	924.35
8	914.95	905.55	911.95	918.35	924.75
9	915.35	905.95	912.35	918.75	925.15
A	915.75	906.35	912.75	919.15	925.55
B	916.15	906.75	913.15	919.55	925.95
C	916.55	907.15	913.55	919.95	926.35
D	916.95	907.55	913.95	920.35	926.75
E	917.35	907.95	914.35	920.75	927.15
F	917.75	908.35	914.75	921.15	927.55

Versions

RF Terminal **RFT9.nnn**

Base Station **DLC9.nnn**

Relay Station **RLY9.nnn**

Australia / New Zealand

There are 16 frequencies available for Australia and New Zealand. These frequencies are displayed as "AUZ Frequency" on the screen at power-up of the Terminal. The frequencies in MHz are:

Freq	MHz	Freq	MHz
0	921.50	8	924.70
1	921.90	9	925.10
2	922.30	A	925.50
3	922.70	B	925.90
4	923.10	C	926.30
5	923.50	D	926.70
6	923.90	E	927.10
7	924.30	F	927.50

Versions

RF Terminal **RFA9.nnn**

Base Station **DLA9.nnn**

Relay Station **RLA9.nnn**

Europe

There are only 9 frequencies available for Europe (UK, Germany, Austria, Switzerland, The Netherlands, Spain, Ireland, Portugal, and Italy). These versions display as "EUR Frequency" on the screen at power-up of the Terminal. The frequencies in MHz are:

Freq	MHz	Freq	MHz
0	433.575	5	433.825
1	433.625	6	433.875
2	433.675	7	433.925
3	433.725	8	433.975
4	433.775		

Versions

RF Terminal **RFE9.nnn**
Base Station **DLE9.nnn**
Relay Station **RLE9.nnn**

Korea

There are only 10 frequencies available for the Korean versions. These versions display as "KOR Frequency" on the screen at power-up of the Terminal. The frequencies in MHz are:

Freq	MHz	Freq	MHz
0	424.725	6	424.875
1	424.750	7	424.900
2	424.775	8	424.925
3	424.800	9	424.950
4	424.825		
5	424.850		

Versions

RF Terminal **RFK9.nnn**
Base Station **DLK9.nnn**
Relay Station **RLK9.nnn**

Frequency Bank (US only)



RF
Setup

Bank 0	0
Bank 1	1
Bank 2	2
Bank 3	3
Bank 4	4

- The default **Frequency Bank** is always **0**. Don't change this unless there are going to be more than 16 Base Stations operating in the same area. If you are using a RF Terminal that is the US version, you can select a different bank, expanding the number of possible frequencies to 80.
- Setup to a Base Station is always done with Bank 0, regardless of the setting. Relays are not supported on any Bank other than 0.
- Switching banks (to anything other than 0) is rarely needed. Additional banks were added to accommodate merchandise marts where many businesses are located under the same roof. This allows each business to operate on a separate frequency, maintaining privacy and avoiding interference from the other businesses also using RF Terminals.
- This setting can be accessed **only** via the keypad Setup.

Relay Existence



RF
Setup

No Relay	0
Yes	1
Search No	2
Search Yes	3

- As shipped, the RF Terminal is not configured to work with Relays. If you want the Terminal to switch to a Relay as you walk out of range from the Base Station, set the **Relay Existence** to **1** (YES).
- Relays will not work on any frequency bank other than **0**. Relays are also not supported in **One-Way Mode**.
- **Site Testing** will work with a Relay, but you must have *only* the Relay active (switching does not take place during Site Testing) - all other Relays and Base Stations must be off. We suggest setting **Relay Existence** to **0** (NO) before doing a Site Test.
- If you want to search for the most powerful Relay each time your RF Terminal "signs on", use setting **3** (Search YES). Otherwise, the Terminal will always

attempt to communicate with the last Relay or Base Station used. The *Search* option is useful when operators finish in one area, turn off the Terminal, and then move to another area to start again.

Security Code



Disabled	0
Enabled	1

- A **Security Code** can be utilized to minimize the possibility of a Base Station listening to data from a Terminal that is talking to a different Base Station. A **Security Code** can also prevent interference from having many Base Station/RF Terminal configurations in one area; i.e. a merchandise mart with multiple vendors all running RF Terminal networks.
- A **Security Code** consists of 3 characters - any combination of ASCII 33 - ASCII 126. This allows for the possibility of more than 830,000 different character combinations. The characters are entered using the bar coded FULL ASCII MENU provided with the RF Terminal. See **Appendix O; ASCII Code Equivalent Table** for the correct corresponding characters.
- Once you press **1** to enable the **Security Code**, you will see the following prompt on the Terminal:

Enter Security Code_

You will be able to see the code as you enter it on the Terminal but once you have moved on to another Setup Parameter, you will only see the status; **0** (disabled) or **1** (enabled) if you go back to it.

- If you forget the **Security Code** that you have already used on other Terminals, the only way to see the code is to go into the Base Setup. This requires that you have full access to the Base Station in order to change the programming jumper. See **Chapter 2** for *Base Station Setup*.
- You can only access the **Security Code** setup parameter by going into Setup Mode via the RF Terminal keypad but you must use the bar coded FULL ASCII MENU to scan in ASCII characters 33-126.

Arrow Keys Only



Other

No 0
Yes 1

- Some customers have requested that the **Arrow Keys** on the RF Terminal keypad be able to generate a response automatically, sending a separate message to the host by simply pressing the appropriate arrow key (without pressing the ENTER key afterward). This allows for simple and fast scrolling by the operator. The default setting is to require the ENTER key to be pressed before data transmission.
- If you set this feature to **1 (YES)**, in order for the RF Terminal to transmit the following values, the corresponding **Arrow Key** must be the *first* key pressed in a data entry sequence. If it is not the first data entered, the arrow key is ignored.

Arrow Key on RF Terminal	Code transmitted to Host
Up Arrow	FS (ASCII 28)
Down Arrow	GS (ASCII 29)
Left Arrow	RS (ASCII 30)
Right Arrow	US (ASCII 31)

The message is sent to the host as:

Bytes	Function	Value
1	RF Terminal ID	0-F
2	Data Transmitted	FS, GS, RS or US
Last	Terminator of Message	CR

LCD Display Mode



Other

6 line display mode 0
4 line display mode 1

WARNING: All Terminals shipped with 6 line displays are configured as **6 line display terminals and will not work in an existing system setup for 4 line display terminals**. If you are currently operating a system that uses 4 line displays and have not changed your program to utilize the 6 line display terminals, **you MUST change the LCD Display Mode to 4 line display** in order for a Terminal with a 6 line displays to SIGN ON to your system.

- As of RF Terminal version 9075, support is included for both a 4 line and a 6 line display. Prior to version 9075, only 4 line display terminals were available. In order to maintain backwards compatibility, 6 line Terminals using version 9075 or greater have the ability to operate as either type of display. If you try to Sign-On with a terminal operating in 6 line mode to a Base with firmware prior to 9075, you will get the message:

Base Reinitialized Cycle Power

By default, the RF Terminal automatically determines which type of display is installed, and sets the LCD Display Mode accordingly.

- The LCD Display Mode should only be changed if you are trying to integrate a new 6 line display terminal into an existing 4 line display system without having to change any of your programming. Our suggestion is to change your program to take advantage of the 6 line display. See the **PROGRAMMING** section for details.

LCD Backlight Display Mode (US only)



Other

No	0
Yes	1

Backlight Display is an optional feature that must be specified at time of order. The default setting is for the LCD Backlight to be OFF. Once you change the setting to 1 for YES, you need to set the *Backlight Duration*.

Backlight Duration (US Only)



Other

Always ON	0
Duration in # of seconds	1-9

The *Backlight Duration* is of no concern unless you have set the **LCD Backlight Display** to 1 for YES. This setting determines how long the Backlight Display is on at startup or when triggered by pressing the F2 key. **Always ON** will create a drain on your batteries and you can expect shorter battery life. Your best bet is to set a time between 1 and 9 seconds and turn it on when you need it by pressing the F2 key.

Skip Opening Screens



RF
Setup

No	0
Go to Two-Way (SIGN ON)	1
Go to One-Way (ONE WAY)	2

- Many users want to skip the opening screens and go directly to SIGN ON or ONE WAY communication once their programs are fully operational. Selecting **1** or **2** will automatically take the operator to the corresponding mode and into your application, skipping the usual Mode Menu (SIGN ON?Y/N, SETUP?Y/N, ONE WAY?Y/N, SITE TESTING?Y/N). If you want to return to the Mode Menu at any time, simply press the F1 key. If you skip the opening screen, you may want to quickly check the settings

of the Terminal without having to reset this parameter, so the Status Key will display four lines (starting with RFX9080) as follows:

mm/dd/yy hh:mm

alkBAT■■■■■■■■■■■■■■■-zz%

alk - when Alkaline batteries are specified in Speaker/Battery setup

rch- when NiMH or NiCad batteries specified in Speaker/Battery setup

zz=percent or battery life left in numbers i.e. 99, 50, 23

Press the **STATUS** key again to resume processing.

The next two lines show the following:

TB9080A ID=0 Freq=0

RLY=N 6/6 SC=N C=N

- The first character on the line is:
 - T** for US/Canada Frequency
 - E** for European (includes UK)
 - A** for Australian
 - G** for old UK (458MHz)
 - K** for Korean
- The next character “**B**” is the board level.
- **9080A** is the firmware version
- **ID** is the Terminal ID assigned (**0-F**)
- **Freq** is the Terminal Frequency (**0-F**)
- **RLY=N** indicates no relays (**Y** instead of **N** indicates Relays are to be sought)
- **6/6** is a 6 line terminal in 6 line mode; other possibilities are **6/4** and **4/4**
- **SC=N** indicates no Security Code is programmed (if **Y**, Security Code)
- **C=N** indicates no Character mapping (if **Y**, beware, characters are remapped)

Host Response Delay

None **00**
Delay, in 1/10 second increments (.1 to 9.9 sec) 01 – 99

- **Host Response Delay** allows you to set a specific amount of time for a Terminal to wait before it attempts to retransmit data. By default, after a RF Terminal transmits its data to the host, it listens for a response from the host for 300ms. If the Terminal does not get a response or gets a "go to sleep" message during that time, it "wakes up" and re-transmits it's data according to the intervals specified below:

Interval	Number of times repeated
½ second	5 times
2 seconds	1 time
4 seconds	1 time
8 seconds	1 time
16 seconds	indefinitely - until prompt received

These "wake up" intervals are fine, especially if your host program processes it's data quickly and gets a new data prompt out to the terminal sometime within the first set of ½ second interval. But if your host program is slow to respond, the continual re-transmissions outlined above generate a lot of unnecessary radio traffic. If your host program doesn't process your data quickly enough to get a new prompt out to the terminal within a 1/2 second, **Host Response Delay** allows you to set a particular delay value that determines the first time the terminal will check with the Base for a new prompt. When you *know* your host program can't respond for 2 seconds, it doesn't make sense to check the host after ½ second and then every ½ sec for 5 times! This will significantly reduce the amount of radio traffic and conserve battery power. Reduced radio traffic also translates into more Terminals per Base and better response times in multi-Terminal networks.

- **Host Response Delay** is particularly useful when multiple Terminals share a Base Station. By specifying the delay and eliminating wasted radio time, the actual average total response time will be less.

Code 3 of 9 (Code 39)



Bar
Codes

Enable Code 3 of 9	0
Disable Code 3 of 9	1
Enable Full ASCII Code 39	2
Disable Full ASCII Code 39	3
Enable Code 39 Accumulate Mode	4
Disable Code 39 Accumulate Mode	5
Enable Start/Stop character transmission	6
Disable Start/Stop character transmission	7
Enable Mod 43 Check Digit	8
Disable Mod43 Check Digit	9
Enable Check Digit transmission	A
Disable Check Digit transmission	B
Caps Lock ON	C
Caps Lock OFF	D

- The Start and Stop character for Code 39 is the * character. Settings **6** and **7** determine whether or not those characters are transmitted to the computer along with the data. For example, at setting **6**, the data of **1234** would be transmitted as ***1234***. Transmitting the start and stop characters can be useful if you need to differentiate between data that comes from a bar code versus data coming from the keypad.
- Enabling use of the Mod 43 check character requires that the last character of your bar code conform to the Mod 43 check character specifications. See **Appendix E; Code 39** for more information. Enable transmission (**A**) will send the check digit data along with the rest of the bar code data to your computer. To use **A**, you must also be using **8**.
- **Caps Lock ON** causes lower case letters read as data to be transmitted to the computer as UPPER CASE, and upper case letters to be transmitted as LOWER CASE. Numbers, punctuation and control characters are not affected. **Caps Lock OFF** means that letters will be transmitted exactly as read. This setting applies to **all** bar code types.
- See **Appendix E; Code 39** for more information regarding **Accumulate Mode**.



Enable UPC/EAN	0
Disable UPC/EAN	1
Enable UPC/EAN Supplements	2
Disable UPC/EAN Supplements	3
Enable transmission of UPC-A NSC or EAN 13 1st 2 digits	4
Disable transmission of UPC-A NSC or EAN-13 1st 2 digits	5
Enable transmission of UPC-A and EAN-13 check digit	6
Disable transmission of UPC-A and EAN-13 check digit	7
Enable transmission of UPC-E NSC and EAN-8 1st digit	8
Disable transmission of UPC-E and EAN-8 1st digit	9
Enable transmission of UPC-E and EAN-8 Check digit	A
Disable transmission of UPC-E and EAN-8 check digit	B
UPC-E0 Compressed	C
UPC-E0 Expanded	D
EAN-8 observing 9&A	E
EAN-8 forced to transmit 8 digits always	F

- Use setting **2** to enable reading of the 2 and 5 digit UPC/EAN supplements commonly found on magazines and paperback books as well as the Extended Coupon Codes. Using this setting force left to right reading of UPC codes to assure that the supplement code is not missed.
- ISBN (International Standard Book Numbering) bar codes are EAN-13 with a 5 digit supplement. If the “Bookland” bar code uses 978 (books) or 977 (periodicals) as the first three digits, then the RF Terminal can transmit it in the ISBN format. The settings for this are found under the *Laser Options* parameter. To enable transmission of the ISBN format, set the *Laser Options* parameter to **D**. To return to the default of normal EAN-13 transmission, set it to **C**. For details on ISBN, see **Appendix J**; *UPC/EAN*.
- Use setting **4** and **9** to enable transmission of the NSC character to your computer. The Number System Character is the leading character in the bar code. For details, see **Appendix J**, *UPC/EAN*.
- Use setting **6** and **A** to enable transmission of the check digit character to your computer. The check digit is the last character and is based upon a calculation performed on the other characters.
- Setting **C** transmits UPC-E0 bar codes as is; setting **D** transmits them with inserted zero’s to make them the same length as a UPC-A bar code. A NSC of 0 is assumed. It is possible to read UPC-E1 bar codes; by default this option is disabled. Do not enable UPC-E1 if you plan on reading EAN-13 bar codes; you may experience partial reads when reading EAN-13. The UPC-E1 option is set in the *2 of 5 Code* parameter. To enable UPC-E1 reading, set the *2 of 5 Code* parameter to **8**. To turn *off* UPC-E1 reading, set it back to the default of **9**.

- If you prefer to transmit UPC-E bar codes in a 6-digit format while EAN-8 is transmitted in its original 8-digit format use setting **F**. This will allow you to use settings **9** and **A** and still transmit EAN-8 as 8 digits.
- UPC-A can be transmitted in EAN-13 format by adding a leading 0 (USA county code) to the UPC-A data. This setting is found in the **Laser Options** parameter. To transmit in EAN-13 format, set the **Laser Options** parameter to **F**. To return to the default (UPC-A transmitted in original format) set it to **E**.

Code 128

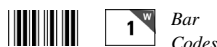

Disable Code 128	0
Enable Code 128	1
Enable UCC/EAN-128	2
Disable UCC/EAN-128	3
Enable Storage Tek Tape Label Code	C
Disable Storage Tek Tape Label Code	D
Bar Code ID's transmitted	E
Bar Code ID's not transmitted	F

- UCC/EAN-128 is a subset of Code 128 that follows certain specifications regarding character content, length and check digits. Enabling UCC/EAN-128 (**2**) causes the RF Terminal to look for a Code 128 bar code that begins with the Code 128 F1 (Function 1) character. See **Appendix H: Code 128** for more details.
- The StorageTek Tape Label code is a proprietary variation of Code 39 code used for the storage of computer data tapes. Enabling the tape label code (**C**) does not disable reading of Code 128 or Code 39 bar codes.
- Bar Code ID's are characters assigned to each bar code type to identify that particular type of code. These Bar Code ID's can be used to identify what type of bar code you are using when you are not sure or you want your application to differentiate between the different types. The Bar Code ID's are assigned as follows:

Bar Code	ID	Bar Code	ID	Bar Code	ID	Bar Code	ID
Codabar	a	1 2of5	e	MSI	j	StorageTek	s
Code 39	b	2 of 5	f	UPC-E(0)	n	Plessey	x
UPC-A	c	Code 128	g	UPC-E (1)	o	LabelCode 4	y
EAN-13	d	Code 93	i	EAN-8	p	LabelCode 5	z

The ID character is transmitted in front of the bar code data.

Codabar



Bar
Codes

Enable Codabar	0
Disable Codabar	1
Enable CLSI Codabar	2
Disable CLSI Codabar	3
Disable Start/Stop character transmission	4
Enable Start/Stop character transmission	5

- CLSI is a form of Codabar often used by libraries.
- Setting **5** will transmit the Codabar *start* and *stop* characters with the bar code data to your computer. If you are varying the start and stop characters to differentiate between different labels, transmitting the start and stop can be helpful. See **Appendix G**; *Codabar* for more information.

2 of 5 Code



Bar
Codes

Enable Interleaved 2 of 5	0
Disable Interleaved 2 of 5	1
Enable Interleaved 2 of 5 check digit	2
Disable Interleaved 2 of 5 check digit	3
Enable check digit transmission	4
Disable check digit transmission	5
Enable Standard 2 of 5	6
Disable Standard 2 of 5	7
Enable UPC- E1	8
Disable UPC- E1	9
Normal decode algorithm (Laser scanners)	B
Loose decode (Symbol LS2000 laser only)	C
Looser decode (Symbol LS2000 laser only)	D

- Setting **2** requires that the last digit in your bar code conform to the specifications for the 2 of 5 check digit calculation. See **Appendix I**; *2 of 5 Code* for more information.
- Transmission of the check digit (**5**) requires the use of setting **2** and will transmit the check digit along with the bar code data to the computer.
- Setting **B** pertains to the decoding algorithms used by the RF Terminal when using a Laser Scanner. In most cases, this should be left at the default **B** setting.
- If scanning through windshields with a laser scanner, (the Symbol LS2000 is the best performer) try setting this parameter to **C** or **D**. Try **C** first, if you still don't have satisfactory results, try **D**.

2 of 5 Length



Default setting	06
Valid entries	00-98
To read variable length 2 of 5 codes	00

- 2 of 5 is so susceptible to misreads that the RF Terminal adds an additional safeguard - it can be configured to look for fixed-length data only.
- The default setting of **06** causes the RF Terminal to read **only** 2 of 5 codes that are 6 digits in length. To set the RF Terminal to read a different length, scan any two-digit number from the bar pad table. For example, to change the RF Terminal to accept an 8-digit bar code, scan **0** then **8** from the bar pad table. 2 of 5 code must always be an even number of digits so the length setting must always be an even number.
- Reading variable length I 2of5 or 2 of 5 codes is to be avoided if at all possible. The **00** setting is supplied for the purposes of reading codes of unknown length, counting the digits and setting the length to the proper number.

MSI and Plessey



Bar
Codes

Disable MSI	0
Enable MSI, 1 Mod 10 check digit	1
Enable MSI, 2 Mod 10 check digits	2
Enable MSI, 1 Mod 11/ Mod 10 check digit	3
Transmit no check digits	4
Transmit 1 check digit	5
Transmit 2 check digits	6
Enable Plessey bar code (mutually exclusive with MSI)	7
Enable LabelCode5 (mutually exclusive w/MSI & Plessey)	8
Enable LabelCode4 (mutually exclusive w/all above)	9

- **LabelCode5** and **LabelCode4** are proprietary bar code types used by Follet.
- If you have enabled the Mod 10 or Mod 11 check digits, they will be transmitted along with your bar code data from the RF Terminal to your host.
- For more information regarding MSI or Plessey Code, see **Appendix K; MSI Plessey Code**.

Code 93



Bar
Codes

Enable Code 93	0
Disable Code 93	1
Enable Full ASCII Code 93	2
Disable Full ASCII Code 93	3

- Code 93 is similar in character set to Code 39. See **Appendix F; Code 93** for more information. Code 93 is not a commonly used bar code symbology.

Preamble



Other

Preambles are user-defined data that is attached to the beginning of data (bar code or keyed) that is transmitted to the host by the RF Terminal. For example, if you set a preamble of @@ and scanned bar code data of **12345**, @@**12345** would be transmitted to the host.

- By default, the RF Terminal has no preambles configured. Preambles can contain up to 15 characters scanned from the bar coded FULL ASCII Menu.

To set a preamble:

1. Scan the **Preamble** bar code or select **Preamble** from the keypad menu.
 2. Scan the desired characters (up to 15) from the FULL ASCII Menu.
 3. Scan the **SET** bar code, or if using the keypad, press **ENTER**.
 4. To clear the **Preamble** and return to the default (no Preambles defined), scan **CLEAR** at step #2, and then continue with your setup.
- You can use the **Preamble** to trim characters from the data you are entering into the RF Terminal. You can trim from 1-15 characters from the data by creating a preamble of:

~x

where ~ is ASCII 126 and *x* is a single hex digit 1-F (corresponding to 1-15). Data that is shorter than the trim amount is transmitted without trimming. **Preambles** trim characters from the front of the data. Here are some examples:

Data	Preamble	Data Transmitted
123	XYZ	XYZ123
12345678	~3XYZ	XYZ45678
12345678	~9	12345678
12345678901	~A	1
123456	~5	6

Preamble trims leading characters

- Using the Bar Code ID feature and the **Preamble**, you can trim data selectively, trimming characters only on the bar code type specified. To use selective trimming, enter:

~bx

where *b* is the Bar Code ID character (see the *Code 128 setup parameter*) and *x* is the number of characters to trim from the front of the data. For example, ~b2~c1 says “trim 2 characters from Code 39 data and 1 character from UPC-A data”. Remember that the **Preamble** trims leading data.

- Lastly, the **Preamble** can be used to check a minimum/maximum data length for bar code data entered. To check for bar code length in the **Preamble** enter:

|nmm

where | is ASCII 124, *nn* is the two-digit minimum and *mm* is the two-digit maximum. |0210 would check for a minimum of 2 characters and a maximum of 10. If you try to scan a bar code outside the minimum or maximum lengths, no decode will result. Entering data by keypad is not affected.

Postamble



Other

Postambles are user-defined data that is attached to the end of data (bar code or keyed) that is transmitted to the host by the RF Terminal. For example, if you set a Postamble of @@ and scanned bar code data of **12345**, **12345@@** would be transmitted to the host.

- By default, the RF Terminal has no Postambles configured. Postambles can contain up to 15 characters scanned from the bar coded FULL ASCII Menu.

To set a Postamble:

1. Scan the **Postamble** bar code or select **Postamble** from the keypad menu.
2. Scan the desired characters (up to 15) from the FULL ASCII Menu.
3. Scan the **SET** bar code, or if using the keypad, press **ENTER**.

4. To clear the **Postamble** and return to the default (no Postambles defined), scan **CLEAR** at step #2, and then continue with your setup.

- You can use the **Postamble** to trim characters from the data you are entering into the RF Terminal. You can trim from 1-15 characters from the data by creating a Postamble of:

~*x*

where ~ is ASCII 126 and *x* is a single hex digit 1-F (corresponding to 1-15). Data that is shorter than the trim amount is transmitted without trimming. **Postambles** trim characters from the end of the data. Here are some examples:

Data	Postamble	Data Transmitted
123	XYZ	123XYZ
12345678	~3XYZ	12345XYZ
12345678	~9	12345678
12345678901	~A	1
123456	~5	1

Postamble trims trailing characters

- Using the Bar Code ID feature and the **Postamble**, you can trim data selectively, trimming characters only on the bar code type specified. To use selective trimming, enter:

~*bx*

where *b* is the *Bar Code ID character* (see the *Code 128 setup parameter*) and *x* is the number of characters to trim from the end of the data. For example, ~**b2~c1** says “trim 2 characters from Code 39 data and 1 character from UPC-A data”. Remember that the **Postamble** trims trailing data.

- Lastly, the **Postamble** can be used to check a maximum character length for data entered. To check for length in the **Postamble**, enter:

|*nnmm*

where | is ASCII 124, *nn* is the two-digit minimum and *mm* is the two-digit maximum. |0210 would check for a minimum of 2 characters and a maximum of 10. If you try to scan a bar code outside the minimum or maximum lengths, no decode will result. Entering data by keypad is not affected.

Characters



This setting allows the RF Terminal to output chosen ASCII characters in place of the actual characters entered. For example, if you scanned the number **1** (*hex 31*) and wanted the RF Terminal to output *hex 92* instead, you would enter **3192** for the **Characters** parameter. This would re-assign the output characters, with the RF Terminal outputting *hex 92* every time it sees *hex 31*. To re-assign characters:

- Scan **Characters**
- Scan up to seven 4-digit pairings where the first 2 digits represent the hex number to *replace* and the second 2 digits represent the hex number to *insert*. You can have up to seven character re-assignments.
- Scan **SET**

You can eliminate the output of a character by using **FF** as the hex number to insert. For example, if you wanted to eliminate all \$, following the above instructions, enter **24FF**.

Beep Tone



Speaker

Lowest	0
Low	1
Medium	2
High	3
Highest	4
No Beep Tone	5

Speaker / Batteries



Speaker

Speaker ON	0
Speaker OFF	1
Alkaline Batteries or Alkaline Rechargeables	2
Nickel Metal Hydride or NiCad Rechargeable Batteries	3

- If you are using the headphone option (T12), you can conserve battery power by turning the Speaker OFF (**1**).
- In order to get an accurate *Battery Status* reading; you must select the correct battery type. The default is Alkaline (**2**). *Battery Status* can be displayed by pressing the STATUS key on the RF Terminal keypad.
- Before you can use rechargeable batteries, you must change the **JP4** jumper inside the RF Terminal. See **Appendix A; Frequency and Jumper Changes** for details.

Date Format



Date/
Time

US Format

0

European Format

1

- The US format of **mm/dd/yy** is the default setting for all models shipped in the US, Canada and Mexico.
- The European format of **dd/mm/yy** is the default setting for the Australian, UK and European models.
- If you switch formats, you must reset the date (**SET DATE**) in the new format also.

Set Date



Date/
Time

For correct date display, the 6-digit date must be set in the date format you plan to use. By default, all US, Canada and Mexico models are using the US date format of **dd/mm/yy**. If you change the date format, you must re-set the date to match the new format. For example, to set a date of January 20, 1999, you would enter 012099 (US format) or 200199 (European format). The date can be scanned in from the bar coded Setup Menu or entered from the RF Terminal keypad. To display the date during operation, press the STATUS key.

Set Time



Date/
Time

The time is set using a 4-digit military **hhmm** format. For example, to set the time to 3:08 p.m., you would enter **1508**. The time can be scanned in from the bar coded Setup Menu or entered from the RF Terminal keypad. To display the time during operation, press the STATUS key.

Display of Year



Date/
Time

2 digit

0

4 digit

1

- By default, the RF Terminal is configured to display and transmit the year in a **2-digit format**; i.e. 1999 would transmit and display as **99**.
- *Before* you change the RF Terminal to display a 4-digit year, i.e. **1999**, make sure that the software receiving data from the RF Terminal is set up to accept a 4-digit year.

Voice Message Partitions



Other

This parameter partitions the total amount of voice messages into different message lengths. The default setting is:

303015

xx yy zz

where: **xx** is number of ½ second messages
yy is the number of 1-second messages
zz is the number of 2-second messages

The total time allotted must not exceed **75** seconds. To change the partitions, scan or enter **6** digits total; **2** for the number of ½-**second** messages, **2** for the number of **1-second** messages and **2** for the number of **2 second** messages. See the default setting as an example.

WARNING: *changing the **Voice Message Partitions** parameter after you have recorded messages could result in having to re-record some of them; they would still be there but longer messages may get cut up and shorter ones combined.*

Shut Down Time



Other

By default, if the RF Terminal is inactive (no keystrokes or scanning) for more than **5 minutes**, it will shut itself down in order to conserve batteries. This includes SIGNING OFF if appropriate. To resume operation, you must turn the RF Terminal back on using the ON/OFF key. To change the amount of time the RF Terminal waits before shutting down:

- Scan **Shut Down Time**
- Scan two digits - the default is **05** (5 minutes)- to correspond to the length of time in minutes. For example, **01** would be **1 minute**.

If you want to prevent the RF Terminal from shutting off automatically at all, set the **Shut Down Time** to **00**.

Laser Scanner Options



Other

None	0
Double Decode	1
4.5 second laser beam	3
Transmit EAN-13 normally	C
Transmit EAN-13 in ISBN format	D
Transmit UPC-A normally	E
Transmit UPC-A in EAN-13 format (with 0 flag character)	F

- By default, the RF Terminal has no special laser options set. If any of the features below seem to fit your situation, set them appropriately. Settings **C** through **F** are not laser-dependent and are for UPC/EAN bar code types only. See the **UPC/EAN** parameter for more information
- **Double Decode** is there to minimize the possibility of misreads when scanning very poor quality bar codes. This option forces the RF Terminal to keep reading until it gets two results that are identical. This "double scan checking" takes longer but will minimize misreads since it must get the same result twice before considering it a "good" read.
- **4-second laser beam** increases the amount of time the laser beam is activated, giving the laser more time to try and read a code. This option is useful for trying to read poor quality code. Using the 4-second laser beam with long range lasers give the operator more time to aim the laser properly at a distant bar code (usually using the "marker" beam). The default beam time is 2 seconds.

Reset



While in Setup Mode, **DO NOT** scan the **RESET** bar code unless you want to set *all* of the RF Terminal setup parameters back to the factory default settings. Scanning **RESET** will erase *all* changes you have made.

The following serial parameters Baud Rate, Parity, Data Bits, and Stop Bits apply only to firmware updates and a portable printer such as the Cameo and Encore printers.

Baud Rate



RS232

300	0
600	1
1200	2
2400	3
4800	4
9600	5
19,200	6

Parity



RS232

None	0
Even	1
Odd	2

- **None** is generally used with 8 data bits, **Even** or **Odd** parity with 7 data bits.

Data Bits



RS232

7 bits	0
8 bits	1

Stop Bits



RS232

1 bit	0
2 bits	1

Protocol



RS232

None	0
XON/XOFF	1
Maintain backward compatibility for illegal statement handling	E
Illegal statement handling for current versions	F

- Settings **0** and **1** pertain to use of a *serial Printer* with your RF Terminal. Use setting **1** for **XON / XOFF** if your *serial Printer* supports it.
- Settings **E** and **F** pertain to the way the RF Terminal handles illegal statements coming from the host computer. RF Terminal software versions *prior* to 9.059 did not handle illegal statements the same way as current versions. **This setting is really only applicable if you had written your host program to be compatible with RF Terminal versions prior to 9.059, are adding current version Terminals to the system, and need to maintain backwards compatibility.**

Base Station Setup

In order to minimize the possibility of accidentally changing the setup of a Base Station when you really meant to change the RF Terminal, the Base Station **cannot** be set up from the bar coded Setup Menu. The Base Station can only be set up from a RF Terminal keypad and requires a jumper change inside the Base Station before you can do so. We made changing Base Station parameters difficult on purpose; any mistake can cut off communication with the host computer and bring your system to a halt. As a safeguard, we suggest turning off all other Base Stations or moving to an isolated area to setup a new Base Station.

Preparing the Base Station for Setup

Before you can set parameters on the Base Station, you must make a hardware change on the Base Station itself.

1. Have all current RF Terminal users SIGN OFF the system.
2. Unplug the Base Station's power supply
3. Remove the cover to the Base Station.

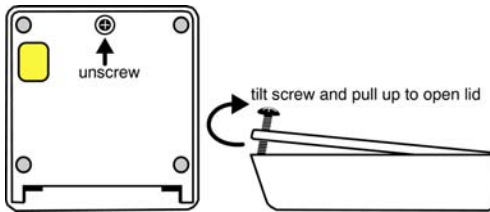

4. Locate **JP103** and move the jumper to the **Programming** position.

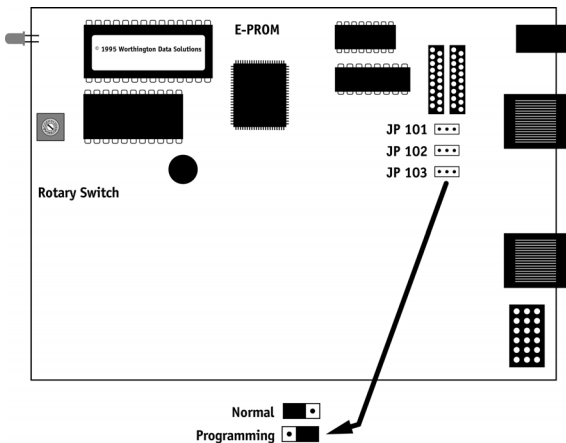

Leave the cover off of the Base Station and plug in the power supply. You are ready to configure the Base Station using a RF Terminal.

Base Station Setup using the RF Terminal

Using a RF Terminal that is on the same frequency as the Base, stand close to the Base Station and turn on the Terminal. The Base Station is setup via the Terminals' keypad by entering *Setup Mode* from the menu. Turn on the Terminal and press any key. Answer NO to all prompts until you see:

**SETUP MODE?
KEY [YES/NO]?_**

Press the YES key. At this point, the terminal will ask for a password:

**SETUP MODE
PASSWORD?_**

Enter **WDTRI** on the keypad. The next item allows you to choose which item to configure:

**R/F Terminal----->1
R/F Base Setup--->2
Voice Operations->3**

Choose **2** for RF Base Setup. If the RF Terminal is communicating with the Base Station, you will see the first Setup Parameter, BAUD RATE displayed on the RF Terminal screen. If you are *not* communicating with the Base Station, you will see the following message:

**Transmission Failed.
To Retry, Move Closer
and Press Enter.
F1 to Exit._**

Move closer and retry by pressing the ENTER key. If you still fail, check that the Base Station is jumpered correctly, is powered up and is on the same frequency as your RF Terminal. If you still have problems, see the Troubleshooting section of this manual.

If you have successful communication, proceed with your Setup. After changing each parameter, press the **ENTER** key to move on to the next parameter.

Base Station Setup Parameters

Typically the Base Station will need no changes.

Baud Rate

300	0
600	1
1200	2
2400	3
4800	4
9600	5
19,200	6

- This is the communication rate between the host computer and the Base Station. The higher the **Baud Rate** the shorter the distance between your Base Station and host computer. **9600** baud (the default) is typically good for 100-200 feet or more, while 19,200 baud cannot be transmitted more than 50-100 feet. If you are planning to use an extension cable of 80 feet or more, cut all pins except *Transmit, Receive, Ground, and Shield*.
- A lot of your success will depend upon the quality of your cabling and the level of interference from other electrical equipment near the cable. Electric motors (on start-up) can be particularly troublesome. If you need more distance, use inexpensive 422 line-drivers.

Xon/Xoff Sensitive

No	0
Yes	1

- If the Base Station is set for **NO**, it transmits ASCII 19 for its' "BASE INITIALIZED" message and ASCII 17 for its' "TERMINAL ID NOT SIGNED ON" message. Unfortunately, these ASCII characters conflict with any multi-user system utilizing the XON/XOFF protocol.
- The alternative setting, **1**, should be used whenever you are operating on a system that is XON/XOFF sensitive, such as an HP3000 or other minicomputers. It causes the Base Station to transmit ASCII 20 (instead of 19) for the "BASE INITIALIZED" message and ASCII 16 (instead of 17) for the "TERMINAL ID NOT SIGNED ON" message.
- The default setting for flow control for a serial port in Windows 95/98/2000/ME is XON/XOFF, so consider using the Alternative Yes setting if running Windows.

Parity

None	0
Even	1
Odd	2

- Set your **Parity** to match what you are using on your host computer.

Data Bits

7 bits	0
8 bits	1

- Set your **Data Bits** to match what you are using on your host computer.

Stop Bits

1 bit	0
2 bits	1

- Set your **Stop Bits** to match what you are using on your host computer.

Base Listening To:

Terminals and Relays	0
Relays ONLY (no RF)	1

- In small networks, the Base Station will always be listening on the RF channel - setting **0**.
- In large networks with critical response-time requirements, it is many times advantageous to have the Base Station listening **ONLY** to Relays. The Base Station then acts as a Relay control unit, passing data from multiple Relays (possibly on different frequencies) to the host computer and back.

Security Code

Disabled	0
Enabled	1

- If you do not currently have a **Security Code** set and want to set one, press the **CLEAR** key, then the **1** key. Set your 3-digit code by scanning the desired characters from the bar coded FULL ASCII MENU. You can choose any 3 characters from ASCII 33 to ASCII 126. If the characters you want to enter are represented on the RF Terminal keypad, you can enter them from the RF Terminal keypad. For example, ASCII 33 ("A") is available on the RF Terminal keypad by pressing SHIFT first, then pressing the # key. ASCII 126, the "~" character is **not** on the RF Terminal keypad and must be

scanned from the bar coded FULL ASCII MENU. You must press ENTER on the RF Terminal keypad when you are finished entering all 3 characters.

- If a **Security Code** is set on the Base Station, only Terminals with the matching **Security Code** will be able to communicate with the Base. A RF Terminal working on the same frequency as the Base Station but *without* the same Security Code is ignored by the Base. Conversely, Base transmissions to a Terminal without the correct **Security Code** will be ignored.
- Once set, **Security Codes** are only visible in the Base Station Setup - they are not visible in the RF Terminal setup once you have entered them. If you forget which **Security Code** you need to use, you must look at the Base setup.

Frequency Bank

Bank 0	0
Bank 1	1
Bank 2	2
Bank 3	3
Bank 4	4

- Changing the **Frequency Bank** is only recommended when more than 16 Base Stations are being used.
- The **Frequency Bank** applies only to the US, Canada and Mexico versions (*DLC9.nnn*) of the RF Terminal and Base Station. This setting allows the available frequencies to increase from 16 to 80. This can only be used in situations where Relay Stations are *not* being used. If you switch the **Frequency Bank** on the Base Station, you must change it on the RF Terminal also. Not only must the **Frequency Bank** match on both the Terminal and Base, but so must the **Frequency** selected.
- Switching banks (to anything other than **0**) is rarely needed. Additional banks were added to accommodate merchandise marts where many businesses are located under the same roof. This allows each business to operate on a separate frequency, maintaining privacy and avoiding interference from the other businesses also using RF Terminals.
- Relays are supported *only* on Bank 0.

Finishing up your Base configuration

Once you have finished configuring your Base Station, press the **F1** key to return to the Setup Menu, then **F1** again to get to the **SIGN ON?** prompt. Unplug the power supply from the Base Station, move **JP103** back to the **NORMAL** position (see diagram at beginning of this section), then replace the cover on the Base Station. Plug the power supply back in to power up the Base. Once the Base Station is powered up, you should be able to SIGN ON from your Terminal. You must always change the jumper and re-power the Base Station for the changes to take effect.

Changing the Base Station parameters from the Host

Once a Base Station has been hung from a ceiling or other high place, you don't want to have to get a ladder every time you need to change one of the Setup Parameters on it. To allow for this situation, there is a way to change all of the Setup Parameters *except* frequency from the host computer. The command for the Base Station Setup follows this format:

@@*S b r p d s l a a EOT

Where:

letter	parameter	possible values			
@@*S	<i>message prefix</i>	always @@*S			
b	<i>baud rate</i>	0=300	2=1200	4=4800	6=19200
		1=600	3=2400	5=9600	
r	<i>XON/XOFF Sensitive</i>	0=NO	1=YES		
p	<i>Parity</i>	0=None	1=even	2=odd	
d	<i>Data Bits</i>	0=7 bits	1=8 bits		
s	<i>Stop Bits</i>	0=1 bit	1=2 bits		
l	<i>Listening to:</i>	0=Terminals and Relays		1=Relays Only	
a	<i>future use</i>	use 0 for present			
a	<i>future use</i>	use 0 for present			
EOT	<i>Host to Base message terminator</i>	always EOT (ASCII 4)			

If the command does not have the exact length of all bytes present and/or any byte does not have a valid value, the command will be ignored. Be careful when using this command as it does change the way you communicate with the Base station. Your program must make the same adjustments immediately in order to resume communication.

Testing the RF link between base station and host

Use the following command to test the transmission of data from host to Base and back again to the host:

@@*Edataaaaaaaaa<EOT>

where *dataaaaaaaaa* is any string of data, terminated by EOT. This string should be sent from the host to the Base Station. If the data is received by the Base, it is echoed back to the host in the format:

dataaaaaaaaa<CR>

where *dataaaaaaaaa* is the data string from the original transmission, terminated by a CR (ASCII 13). This test verifies communication in both directions (host to Base, Base to host).

- If the data isn't echoed back, either your host COM port or the Base Station has a problem. Check that the Base Station is **NOT** jumpered for Programming. JP103 should be set to **N**, (Normal), not P. If it is set to P, no communication from host to Base and back will take place.
- Once you know the Base Station is communicating with the host correctly, compare the frequency of the Base Station with the frequency of the Terminal. Use Site Testing to check the communication of the Terminal to the Base and back. Stay close, make sure no other Terminals are in use, and go to Site Test mode on the Terminal. You should get 96-100% on first try. If you don't, it's a good chance your radios need repair. Call Worth Data for an RMA.

If you are using PICK or UNIX as your operating system, make sure the Base Station is set to "XON/XOFF Sensitive".

Chapter 3

Operational Theory

Before you jump in and start writing a complex host program, it might be nice to be familiar with the theory behind the operation of your RF Terminal. The RF Terminal has three different modes of communication:

- **Two-Way Mode** - the host program transmits requests for data to the terminal via the Base Station. The RF Terminal transmits a response back to the Base Station, which in turn sends the data on to the host program. This is a truly interactive mode allowing you to create flexible programs for a variety of applications that are computer led and controlled.
- **One-Way Mode** - the RF Terminal transmits to the host with only confirmation from the Base Station. The host program receives data from the Base Station as it would any other serial device. The host cannot send data to the terminal; it can only receive information.
- **Site Test Mode** – the Base Station and RF Terminal work together to evaluate the site and determine the best location for the Base Station. The site test evaluates the percentage of successful transmissions on the first and second tries from any given area. The higher the percentage, the more successful your communications will be from that area. This helps you to identify problem areas before you implement your RF Terminal system. At 30 ft., this is also the acid test for suspected bad radios in a base or in a terminal.

Let's start with a discussion of the basic theory behind a **Two-Way** RF Terminal system.

How the Two-Way RF System works

Basic RF System communications...

The RF system consists of three components – *Host Computer*, *Base Station* and *RF Terminal*. The *Base Station* connects to the *Host Computer* via the serial port. The application running on the *Host Computer* sends a data prompt to the serial port where the *Base Station* receives it. The *Base Station* then transmits the data prompt via radio frequency to the intended *RF Terminal*. The *RF Terminal* displays the data prompt on the display and waits for the operator to enter the requested data. Once the operator enters his data, the *RF Terminal* transmits the data to the *Base Station*, which in turn passes it on to the *Host Computer*. The application on the host computer processes the information and sends a new data prompt out to the *Base Station* and the whole process begins again.

A little more in depth...

This RF system's dialogue is Terminal initiated. The Terminal says, "I'm here, give me something to do. It is not designed for the Terminal to listen all day to see if the host has something for it, unless the host sends out a message such as "STAND BY, PRESS ENTER". Then the Terminal will go to sleep and wake up every few seconds to see if there is anything to do while displaying the message "WAITING ON HOST PROMPT." (After the terminal goes to sleep 8 times, it only wakes up and asks every 16 seconds though.)

The Worth Data RF system is different from other systems in that our RF Terminal does not constantly "listen" for a data prompt from the host. Other systems are constantly waiting for a prompt from the host, using up valuable battery life. We decided to use a different approach that would help to eliminate unnecessary radio traffic, conserve battery power, and reduce the size of the actual Terminal itself.

Here is how it works:

Each RF Terminal has a **Terminal ID**. When the RF Terminal powers up, it asks if you want to **SIGN ON?** Pressing YES at the **SIGN ON?** prompt causes the RF Terminal to transmit its **Terminal ID** and a byte of data indicating to the Base Station that it wants to sign on to the system.

When the Base Station receives a **SIGN ON** message from a RF Terminal, the Base Station transmits the SIGN ON information to the host computer. The host computer application can then do one of two things:

1. If it has something for the Terminal to do, it can send a prompt to the Base, which in turn transmits it to the Terminal. The RF Terminal receives the prompt, waits for the operator to enter the requested data, and then transmits the data back to the Base Station.
2. If the host program does nothing within an allotted time, the Terminal displays the message:

WAITING ON HOST PROMPT

Lets suppose that a RF Terminal and a Base Station have been processing data by sending prompts and data back and forth as described in example 1. The Base Station sends a data prompt to the RF Terminal, the RF Terminal transmits the operator-entered data back to the Base Station. If the host program has another prompt for the terminal, the Base sends it out, repeating the process above.

Suppose the host program does *not* have a prompt ready to send back to the Terminal; the Terminal transmits its data to the Base Station but does not receive a new data prompt. The Terminal then retransmits its data (it thinks maybe the host didn't receive it) and waits for a response.

The Base Station knows that the data is a retransmission rather than a new data transmission so it sends a message to the Terminal telling it “I have nothing for you from the host, go to sleep”.

While in “sleep” mode, the Terminal “wakes” up at specific increasing intervals and asks “do you have anything for me yet”, waiting for either a “go to sleep” message or a new data prompt. These are the “wake up” intervals:

Interval	Number of times repeated
½ second	5 times
2 seconds	1 time
4 seconds	1 time
8 seconds	1 time
16 seconds	indefinitely - until prompt received

After each delays, the Terminal displays:

WAITING FOR HOST PROMPT

Waiting ½ second the first time before asking the base “do you have anything for me yet?” is OK for most rapid response host programs. If your host program is slow and doesn’t process your data quickly enough to get a new prompt out to the terminal within 1/2 second, you need to set a new time by specifying a *Host Response Delay*.

Host Response Delay allows you to set a particular delay value that determines when the terminal will check with the Base for a new prompt. This is valuable if you know that your program cannot respond for a certain amount of time. If you know your host program can’t respond for 2 seconds, there is no need for multiple times after ½ second; that creates unnecessary radio traffic that results in unnecessary collisions and a decrease in system response time. It also wastes battery power. *Host Response Delay* is critical to eliminating contention between multiple terminals on one Base Station. See *Chapter 2; RF System Setup* for details on setting the *Host Response Delay*.

If a Terminal receives *no* response at all from a Base Station (no data prompt or “go to sleep” message), it retransmits its data and waits for a response. If the Terminal gets no response after 10 re-transmissions, it displays:

**TRANSMISSION FAILED
HIT ANY KEY_**

Pressing a key on the Terminal starts the re-transmission process over again. The RF Terminal will try to retransmit its data, displaying the TRANSMISSION FAILED message after every 10 unsuccessful tries.

How the One-Way RF System works

The RF System can be used to perform “dumb” data entry to the computer – you could even use *Portkey* to transmit the data as though it has been entered from the keyboard. This is useful if you want to enter data directly into an application. This type of data transmission is called **One-Way Mode**. Once the RF Terminal transmits data to the Base Station, the Base Station acknowledges receipt of the information by echoing back the data to the Terminal that sent it, along with a beep. If the data transmission *did not* make it through to the Base station after 10 tries, the RF Terminal will give two long beeps and display the following message:

**TRANSMISSION FAILED
TO RETRY, MOVE CLOSER
AND PRESS ENTER.
F1 TO EXIT.**

One-Way mode also works well as a “demo” program since it doesn’t require a program running on the host computer or even that the Base Station be connected to the host. If you want data to display on the host computer, simply run a program such as Windows’ *Terminal* (be sure to disable Xon/Xoff) or our *Portkey* program (for keyboard emulation). To get into **One-Way Mode**:

At power up, the RF Terminal asks if you want to

**SIGN ON?
KEY [YES/NO]?_**

SIGN ON is for Two-Way communication only. Press NO, then press NO again at:

**SETUP MODE?
KEY [YES/NO]?_**

When you see:

**ONE WAY MODE?
KEY [YES/NO]?_**

Press YES. If the Base Station already has other RF Terminals signed on in Two-Way mode, you will not be allowed into the system. A Base Station must be dedicated to one mode at a time.

If the Base Station is dedicated to One-Way mode, you will see the following prompt on the RF Terminal display:

**Data Received Was
Enter Data?**

Since you have just started your One-Way session, there is no data to display on line #2. Line #3 is now asking you to scan or key data into the RF Terminal. If

you are entering data from the RF Terminal keypad, you must press the ENTER key to transmit your data. If the Base Station receives the data, the RF Terminal displays the following prompt:

Data Received Was
aaaaaaaaaaaaaaaaaaaa
Enter Data?

Where *aaaaaaaaaaaaaaaaaaaa* is the data received by the Base Station (and transmitted to the Host Computer if connected). You can exit One-Way Mode simply by pressing the F1 key on the RF Terminal keypad.

In One-Way Mode, the RF Terminal transmits its *Terminal ID* to the Base Station but it *does not* pass it on to the Host Computer. If your application on the Host Computer needs to know which RF Terminal data came from, use the *Preamble* setup parameter to enter unique identifying information. Data is also transmitted *without* a *Terminator Character* (like a CR or TAB that is transmitted after the data); so if you need one, use the *Postamble* setup parameter to add the appropriate character(s) after your data. For more information on *Preambles* and *Postambles* see *Chapter 2; RF System Setup* for details.

How Site Testing works

The RF Terminal uses **Site Test** mode to: 1) test the radios at short range, (30 ft.) as an acid test for correct operation, and 2) to evaluate a specific site for effective coverage. Because each operating environment is different, it is almost impossible to predict the range without **Site Testing**.

Before you permanently install any hardware, you should perform a Site Test to fully evaluate your planned area of operation. During the test the RF Terminal is transmitting 50 messages and waiting for acknowledgement from the Base Station. The Site Test evaluates the percentage of successful transmissions on the first and second tries from any given area. The higher the percentage, the more successful your communications will be from that area. Site Testing does not require your Base Station be attached to your Host Computer. All you need is your Base Station, 5v power supply and RF Terminal. For detailed information on how to perform a Site Test and use the results to determine the best location for your Base Station, go to **Chapter 4; Performance Issues**.

Chapter 4

Performance Issues

Evaluating your area of planned operation

Since every operational environment is different, it is impossible for us to tell you exactly what equipment you need and where you should put it to achieve maximum performance from your RF System.

Site Testing was developed so that the user could start with a minimum system (RF Terminal and Base Station) and determine for themselves what their realistic operating range is, what additional equipment they need, and where to install their Base Stations to achieve optimum performance. Some other manufactures require expensive Site Tests before you can even purchase any equipment from them. Our Site Testing allows you the flexibility to Site Test whenever you choose, whether it is before you install your system or during operation to troubleshoot RF problems. Site Testing is the most valuable tool you have to help you achieve an efficient RF System with maximum range.

There is also some basic information about Radio Frequency itself that can help you make smart choices about the location and composition of your system:

- **Metal walls are almost impenetrable by RF.** If your warehouse computer is located in a metal shed, don't locate the Base Station inside with the computer. Run a serial cable *outside* the metal shed and locate the Base Station there instead. Elevator shafts have similar signal-blocking problems.
- **The more walls you try to transmit through, the more the signal breaks down.** Walls that have metal studs (interior office walls) and concrete walls with steel rebar slightly degrade the signal with each wall you try to go through. Metal walls may require the use of Relay Stations to achieve adequate range.
- **Organic material absorbs RF energy.** If you are trying to operate in an area with lots of densely packed organic material (bags of beans or corn), expect and plan for reduced operating ranges.
- **900MHz Spread Spectrum Phones.** These phones will choke all frequencies that the RF Terminal uses. Switch to 2.4GHz phones. They are cheap to replace.

There are some additional measures (other than a Site Test) you can take early on to maximize your range:

- **Base Stations should be located at the center of the area of intended coverage.** This applies to Relay Stations also (see later in this chapter for more about Relays). If they are not located in the center, they should be tilted in the direction of use.
- **Raise the Base Station.** Sometimes just raising the Base Station 12 feet will dramatically increase your operating range, especially in a warehouse or grocery store environment. Mount the Base Station on the ceiling with the antenna pointing down if you can.
- **Make Sure All Terminals are at least up to RFX9077J.** This firmware and later releases reduce the radio contention by 50%.

Performing a Site Test

As we have said before, the Site Test is your most valuable tool for evaluating your planned area of operation. All you need to perform a Site Test is a RF Terminal, a Base Station and its 5v power supply. There are a few things you need to do though before you begin:

- Make sure **all other** Base Stations and Relays are turned **OFF**.
- Make sure that the Base Station and RF Terminal you are using are set to the same frequency. Base Stations and RF Terminals are shipped from the factory set to frequency 0. If you need to change the frequency, see **Appendix A; Frequency and Jumper Changes**.
- It is best to have a site map and several different colored pens to record the results of your testing. Each time you move the Base Station, record it's location on the site map using a different color pen. Use the same color pen to record the test results for that Base location.

The Base Station does not need to be connected to a host computer to do a Site Test. Simply connect the Base Station to wall power using the 5v power adapter. Locate the Base where you think you will have the best range and power it up. Turn on the RF Terminal and press a key at the opening screen.

- Press **NO** at the **SIGN ON?** prompt
- Press **NO** at the **SETUP MODE?** prompt
- Press **NO** at the **ONE WAY MODE?** prompt
- Press **YES** at the **SITE TESTING?** prompt

If the Base Station is powered up, walk to the area where you want to perform your first test. When in position, stop and look at the RF Terminal display. It should read:

**Press Enter When
Ready, F1 to Exit**

Press the ENTER key to start the test. Hold still during the test – moving around can result in inaccurate results. During the test the RF Terminal is transmitting 50 messages and waiting for acknowledgement from the Base Station. During the test the following message displays on the RF Terminal screen:

**Site Testing in
Progress, Please
Wait.....**

Please Wait... will display on your screen until the test is finished. If it takes more than a few seconds, there is something wrong. When the test is finished, you will see the results displayed in the following format:

**1st Try nn% Good
2nd Try mm% Good
Press Enter When
Ready, F1 to Exit**

The first line shows the percent of successful transmissions on the first try. The second line shows the percent of successful transmissions on the second try. If you are planning to use only one RF Terminal, even 50% successful on the second try is probably tolerable for most applications. If you were planning to use several RF Terminals in your system, 50% would result in long delays and would not be acceptable.

Here are some rough guidelines you can use to evaluate your results:

Number of Terminals in a given area	Minimum Acceptable Percentage
1	75% on 2nd try
2	90% on 2nd try
3	98% on 2nd try
4	80% on 1st try
5-8	95% on 1st try
9+	98% on 1st try

If you don't get the minimum results shown above:

1. Try hanging the Base Station upside down or tilted toward the area of usage – this alone can double the effective range.
2. If you are close to the Base Station and your results are very poor, try a different frequency. You may find less interference on another channel. There are many to choose from, only try 1 or 2 others.
3. Try locating the Base Station closer to the area of difficulty. Remember that moving the Base Station will require you to recheck the other locations already tested.

4. Plan for a Relay Station. Move the Base Station to where you would expect to place the Relay and try again.

Relay Stations

Keeping all of the above factors in mind, using Relay Stations can increase your area of coverage by 5 times. Relays work like a remote antenna, passing data to the Base Station via cable instead of radio frequency. They don't support **Frequency Banks**. Base Stations cannot be used as a Relay Station without changing the firmware and the jumpers inside.

Relay Stations are attached to the Base Station using a cable that connects from the Base's RELAY port to the Relays' RELAY port. When you order a Relay Station, you receive a 3-foot test cable with it. Although Relay Stations will increase your range of operation, they will also add about 1/2 second to the response time.

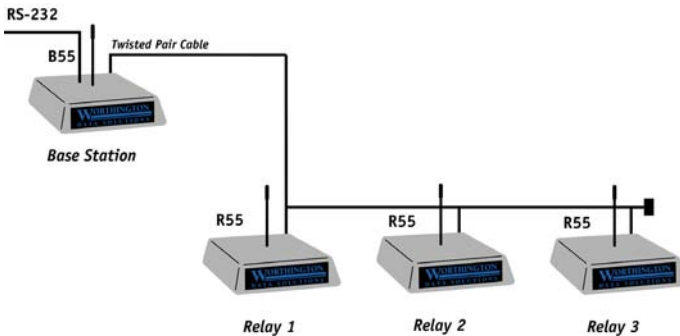

How Relay Stations work...

It helps to know how Relay Stations work before you add them to your system. Although Relays increase your operational range, they also slow the response time of your system. In order to use Relays, the Terminal must be configured to acknowledge that Relays are present. This is done using the **Relay Existence** setup parameter. By default, the RF Terminal is *not* configured to look for Relays. This setup parameter can only be accessed via the RF Terminal keypad - it cannot be configured using the bar coded RF Terminal Setup Menu. See **Chapter 2; RF System Setup** for details.

Once the RF Terminal is Relay-ready, it can use the Relay instead of the Base Station to communicate. If a RF Terminal tries to transmit 10 times to a Base Station without a response, it broadcasts a "who can hear me" message. If both the Base Station and the Relay hear the message, whoever answers back to the RF Terminal first becomes the point of contact for that RF Terminal.

Once a RF Terminal has established communication with a Relay, it addresses that particular Relay until another communication failure (10 transmissions with no response) occurs. If a Base Station is within hearing distance of the RF Terminal, it will ignore messages meant for the Relay.

When a Relay receives data from a RF Terminal, it then transmits that data to the Base Station over RS-422 twisted-pair cable. The Base Station in turn transmits data (via cable) for that RF Terminal to the Relay, for subsequent broadcast to the RF Terminal.

Relays are “dumb”. Relays do not know whether a transmission was received by the Base Station or not, so it is up to the RF Terminal to retransmit its data if it does not receive a message from the Host Computer (via the Relay). The Relay can recognize data from the Terminal though and if it receives 10 re-transmissions from the RF Terminal, the Relay assumes that the Base Station cannot hear it and broadcasts the message:

**RELAY *n* CANNOT BE
HEARD BY THE BASE
NOTIFY SUPERVISOR
PRESS ANY KEY**

At this point, the RF Terminal puts out the “who can hear me” message. The **RELAY *n* CANNOT BE HEARD** message usually indicates a cabling problem and should be checked out immediately.

Sometimes a Relay gets a response from the Base Station that is partial data or garbage. The Terminal retransmits its data since it has not received a new prompt. If this occurs ten times, the RF Terminal broadcasts, “who can hear me”. At this point the Relay is still functioning and answers the RF Terminal’s call. Should the Relay respond to the RF Terminal first, the whole sequence starts again. If the Relay *again* gets “garbage” messages from the Base and the Terminal re-transmits 10 times, then the Relay concludes that there is something wrong and broadcasts the RELAY CANNOT BE HEARD message. This situation indicates that you may have an electrical “noise” problem – check your cabling as well as any electrical equipment that is in the area.

Determining coverage areas for Base Stations and Relays

As we said before, it is almost impossible to predict the effective RF communications range in a given environment. The typical area of coverage is a 400-1000 ft. radius.

After a Site Test, if you have determined that you will need to add Relays to cover the area you want to operate in, you will need to determine where to place your Relay in relation to your Base Station. To effectively cover an area, there must be overlap between the area covered by the Base Station and the area covered by the Relay. The example below shows what can happen with no area overlap:

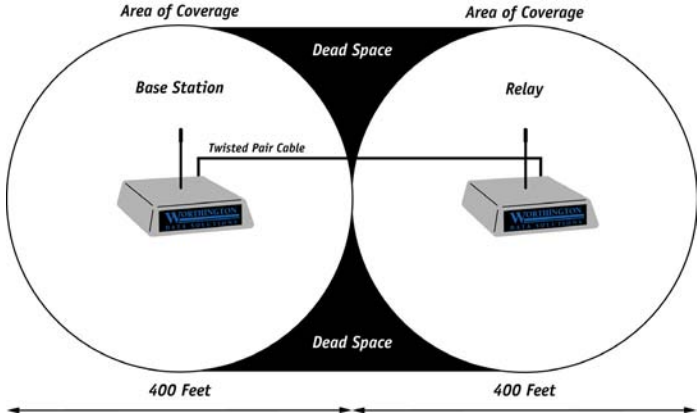

As you can see, the only area adequately covered is in a path where the two circles touch. The “dead space” is completely without coverage. Alternatively, locating the Base Station and Relay as shown below results in better coverage: To Site Test a Relay, all other Relays and Base Stations must be turned off.

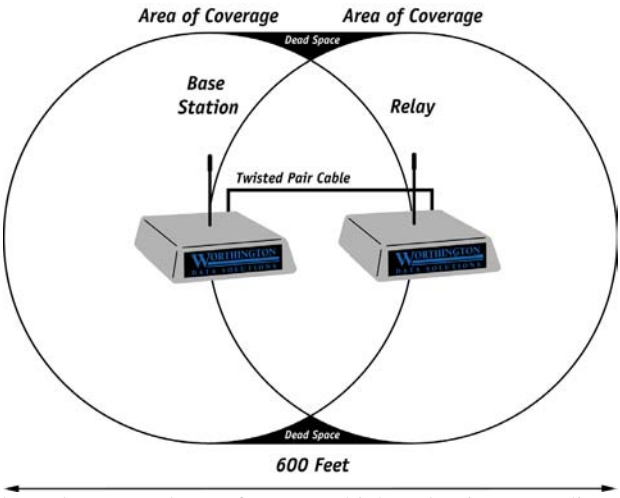

This is the only way to know for sure which Relay is responding. Alternatively, perform the Relays’ test out of range of the other Relays and Base Stations.

Relay Installation

Relay Stations are connected to the Base by twisted-pair wire. See **Appendix B: Adding Relays** for the pin outs and a testing plan.

Dealing with radio traffic contention

Radio traffic contention is the other most common hardware related problem you may have. If tested and configured properly, a single RF Terminal operating with a single Base Station should be no problem. Regardless of how frequent the scanning or data entry, radio signal contention is not a serious problem with two terminals per base. But if you have multiple terminals on a Base and two terminals happen to transmit exactly at the same time, a collision will occur and neither transmission will get through to the Base without automatic re-transmission and associated delays.

Operating with multiple terminals on one Base station increases the chance for delays due to radio signal contention. A typical RF Terminal application consists of scanning or data entry followed by movement (i.e. going to another area) or manual activity (i.e. loading items in a truck) lasting several seconds. This means there is usually several seconds between each data transmission on a Terminal. The number of seconds between data transmissions on a Terminal determines the number of Terminals that can share the same frequency without significant delays.

The following chart outlines the number of terminals possible on a Base Station based upon the “average” transaction rate: (this chart assumes a firmware version of RFx9077J or higher)

Average number of seconds between transactions on a single Terminal	Number of Terminals possible on same frequency/Base
1	2
2	4
3	6
4	8
5	10
6	12
7	14
8	16

Be very careful when coming up with an “average” time between transactions. You should always use an average based upon your peak activity time. For example, let’s say that your business operates from 7 am to 5 p.m. Your RF Terminal operators start scanning at about 7:00, working continuously, averaging 3 seconds between transactions until 10:00, when operators begin taking breaks or moving on to work on other projects. Scanning is slow until 5:00, averaging 16 seconds between transactions. If you take an average over the whole day, your average would appear to be about 12 seconds between

transactions, and using the chart above, you would assume you could safely run 16 terminals from one Base. But what about the peak time of 7:00 to 10:00, when transactions are only 3 seconds apart? Running 16 terminals per Base would cause significant delays during your peak time, extending the amount of time it takes to do the same amount of work. The safer bet is to use your peak time to calculate your average; in this case, you could efficiently run 6 Terminals on each Base without significant delays.

Each Base station can accommodate up to 16 terminals - as you can see, the restricting factor is the number of transactions you need to perform per second. If the number of Terminals you can run based upon the average transaction time isn't acceptable, you need to add another Base station (or 2, depending upon what an acceptable transaction time is for you) and split your terminals between them. High volume systems probably require additional Base stations. Adding an additional Base station requires another serial port(s) or even another host computer in many instances. Only one Base station per serial port is allowed - you cannot multi-drop or daisy-chain Base stations. Each Base station (and it's associated terminals) operating in a given area must also be operating on a different frequency. A common configuration has multiple workstations running a network application, with each workstation running a Base station and associated terminals on a unique frequency.

The great thing about the RF Worth Data R/F Terminal system is that you can easily add additional Base stations at very low cost.

Chapter 5

Before you begin programming...

The RF Terminal operates in two basic ways:

One-Way communication, where all data transfer is initiated by the RF Terminal. The Base Station itself simply acknowledges the receipt of the data by echoing it back to the Terminal. The host computer has no dialog whatsoever with the Base Station or Terminal; it is simply used to take the data coming from the Base through the serial port and do something with it.

Two-Way communication, where messages from the host user program are sent to the Base Station (via the serial port), then from the Base Station to the RF Terminal. The Terminal responds back to the Base with data and its Terminal ID. The data is then transmitted from the Base to the host computer where it is processed and the next command is sent out. Each RF Terminal has a unique Terminal ID, allowing a single Base Station to handle up to 16 Terminals.

Two-way dialog is established when a Terminal SIGNS ON to the RF network. The host computer application waits until a Terminal SIGNS ON, then begins its processing by sending the first prompt out to the Terminal via the Base Station. If the Terminal does not receive a prompt from the host, it goes into “sleep” mode, “waking up” and checking with the Base periodically (see **Chapter 3**; *Operational Theory* for details) to see if it has any messages waiting. This conserves battery power and reduces radio traffic.

Two-Way mode requires programming to communicate with the Terminal where One-Way mode does not. We have tried to make it easy for the programmer to communicate with the Base Station; no protocol or handshaking is required. This type of communication is fine when the Base is located only a few feet from the serial port it is connected to. If you are locating your Base Station farther away, use shielded, grounded (bare wire Pin 1 touching shield) cable, lower baud rates and possibly, line drivers for very noisy environments.

Before you begin programming, there are some factors you should take into consideration during the planning process.

- **Plan for system failures.** This includes hardware failures, software failures and operator failures. In order to create an efficient application, you must put some thought into what you will do when different parts of the system fail.

- **Look for All Errors.** Be sure your program is trapping all possible error conditions that the Base Station may return to you. The list includes:

Sequence Errors detected
Illegal Command detected
Base Station Initialized
Addressing a Terminal Not Signed In
Command without an ID

All of these error conditions are detailed in the next chapter. Don't forget to program for them; this is a common mistake.

Even though you don't think your code will ever make a mistake, take advantage of feedback that the Base Station provides. Failure to do so is a common mistake.

- **Parse the Returned Strings thoroughly.** Don't assume anything about the next response from the Base to your program and look only for the partial string such as the ID only; parse the string returned completely and be sure you are examining every possibility. Failure to do so is a common mistake.
- **Plan for expansion.** You may start small (1 base/1 Terminal) but try to create an application that will allow for easy expansion and addition - especially of Terminals.
- **Use the Demo Programs.** The demo programs can at least allow you to see how the system functions and whether you can anticipate any system-wide problems. The demo programs should also be used as a response-time benchmark.

Failure Planning

Hardware Failures

Let's assume that each part of the system has failed. How are you going to know what has happened and how are you going to recover?

- The most frequent failures are at the Terminal level. If a Terminal has a hardware failure, it will not be able to SIGN OUT. It is possible for the Terminal operator to press the ON/OFF key or the F1 key by accident, forcing the Terminal to SIGN OUT - sometimes in the middle of a transaction. This happens at battery-changing time also. You need to plan for partial transactions - do you trash the data you do have and start over, or pick up where you left off?

- Keep in mind that if a Terminal has SIGNED OUT in mid-transaction, the Base Station clears any pending message for that Terminal before it will allow it to SIGN ON again. Make allowances to re-send messages or prompts that were cleared upon SIGN ON if necessary.
- If a Base Station has a hardware failure, neither the Terminal nor the host computer will be able to communicate with it. When the Base Station comes back on-line, it sends a “Base Station Initialized” message back to the host, letting the host know that it must re-initialize all Terminals and pick up any incomplete transactions.

Operator Errors

- Plan on your operator walking out of range and going to lunch in the middle of a transaction. What do you do with the data you do have, and where are you going to start up again?
- Let’s say your operator is SIGNED ON and decides it’s time to take a break. Instead of pressing the F1 key to SIGN OUT, he presses the OFF key. Pressing the OFF key is OK (it will SIGN him OUT) but there is a delay until the SIGN OUT is acknowledged. Because of the delay, the operator might think he didn’t press the key hard enough and press it again - this time actually powering down the Terminal *before* the SIGN OUT was complete. If this happens, you need to plan to *re-send* the last prompt to the Terminal when he SIGNS ON again.

Chapter 6

Programming for the RF Terminal

The four levels of programming support offered for the RF Terminal are:

- 1) Low Level ASCII sequences sent to and from the Base Station by the user program reading/writing to the serial port.
- 2) Low Level ASCII sequences sent to and from the Base Station using DLL for Windows for serial port reading/writing.
- 3) Active X drop-in components. Every necessary function is defined. You just complete the code for each function.
- 4) TCP/IP Active X drop-in components used by the “Server” computer to communicate with the “Client” computer that has the Base Station(s) attached.

LOW Level ASCII sequences directly

Planning

Remember, plan for every error that the Base Station might return including:

Sequence Errors detected
Illegal Command detected
Base Station Initialization detected
Addressing a Terminal Not Signed In detected
Command without an ID

Programs can be written in any language that has access to the serial port (reading/writing), regardless of the platform. No more than one Base Station is allowed for each serial port.

Host to Terminal Programming

The basic format of a message that is transmitted from Host to Base to Terminal is fairly simple:

Byte position	Function	Possible values
1	RF Terminal ID	0-F
2+	Command(s)	**
Last	Termination of message	EOT (ASCII 4)

The **RF Terminal ID** is always the first byte and always only 1 character in length. There are 16 different possible values - the numbers 0-9 and the letters A-F.

The **Command(s)** section of the message always starts with the second byte and can consist of one or more commands - including data to be displayed or voice messages to be broadcast.

The last byte is always ASCII 4 (**EOT**) to terminate the message. Here is a listing of valid commands and examples:

Command characters	Command function
*@	Reinitializes all terminals
3@	Reinitializes Terminal #3
1@Bn	Make Terminal #1 beep <i>n</i> (1-9) times
2@C0 *	Clears the entire screen (4 lines or 6 lines) on Terminal #2. *See more about 4 and 6 line displays on page 6-4.
0@C1	Clears line 1 on Terminal #0
1@C2	Clears line 2 on Terminal #1
2@C3	Clears line 3 on Terminal #2
0@C4	Clears line 4 on Terminal #0
3@C5 *	Clears line 5 on Terminal#3 (if 6 line display), Clears all lines if 4 line display. *See more about the two display types on page 6-4.
1@C6 *	Clears line 6 on a 6 line display. Will do nothing on a 4 line display. *See more about 4 and 6 line displays on page 6-4.
1@Dn	Displays date and time on line <i>n</i> (1-4) in US (mm/dd/yy, hh:mm:ss) or Euro (dd/mm/yy, hh:mm:ss) format on Terminal #1
1@Vnn	Play voice message # <i>nn</i> (01-99) on Terminal #1
1@Sdataxxx	Output <i>dataxxxxxx</i> to serial port on Terminal #1 -max 255 chs

A typical “prompt” command sequence follows the format below:

0@n,m,o,data

where

- n** is the line number (1-4) you want the prompt displayed on
- m** is the character position (1-20) where you want the prompt displayed
- o** is the character that determines whether the prompt is for **display only** (0) or is **waiting for data input** (1) See the table below for valid characters for this position.
- data** is the data you want displayed

For example, the command **@1,1,1, Enter Quantity** would display **Enter Quantity** starting at position 1 on line 1, then wait for the operator to enter their data.

These are valid entries for the third position character:

0	No data input for this Command, Display ONLY
1	Data input required from the keypad or scanner
2	Only keypad input allowed, start un-shifted
3	Only keypad input allowed, start SHIFTED
4	Only scanner input allowed
5	Only accept YES (Enter key or C key) or NO (0 key or B key) keypad response. (Terminal sends 1 for YES, 0 for NO). C and B key are there to facilitate YES/NO keypad entry while scanning with integrated laser.
A	same as 1, but time stamped as prefix (hhmmss)
B	same as 2, but time stamped as prefix (hhmmss)
C	same as 3, but time stamped
D	same as 4, but time stamped
E	same as 4, but can press END key to break-out of scanner-only input mode. Terminal ID + CR is sent to host
S	SHIFTED keypad input or scanner input
p	un-shifted keypad entry with no display (for passwords)
P	SHIFTED keypad entry with no display (for passwords)
R	Data input required from the RS-232 serial port (waiting for serial input can be bypassed by pressing the ENTER key which will send a NULL data string back to host computer.) Uses for this are PDF 417 Serial Scanners, and the Cameo Printer's magnetic stripe input. A POS terminal becomes possible. Scan the credit card and print the receipt, all on the RF Terminal.

Here are some rules and useful tips for creating messages (one or more commands per message):

- Re-initialize commands ***@**, or **n@** (where **n** is the Terminal ID 0-F) clear the buffer for terminal(s) in the Base Station. Following a re-initialization, the host program should re-display of all the screen data necessary to start the application.
- A message with multiple commands is legal and useful. For example, the command “@1,1,0, PLEASE ENTER@2,1,1,QTY” would display PLEASE ENTER on line 1, display QTY on line 2, and then wait for data input. All 6 lines can be filled with one message.
- Messages can be a combination of multiple commands, (i.e. voice messages, initialization, clearing lines, requesting data entry), up to 247 characters in length. A message cannot though, contain an @S command in combination with any other command. A message also **should not** contain more than 1 request for data entry (third character in command is 1). For example:

@1,1,1,ITEM@2,1,1,QTY

has two data entry “prompt” commands combined. If this message were sent to the RF Terminal, the first data entry prompt (@1,1,1,ITEM) would be executed, but any and all commands after the first data entry prompt in that statement would be ignored without warning – there will be no display or indication of an illegal command.

- The @S command (for serial output) statement *cannot* be combined with any other command - even clear (@Cx) commands. After a @S command is successfully completed, the Base Station sends back to the host the RF Terminal ID followed by a CR (ASCII 13). There is a 247 character limit on data for this command. If you send a command of more than 247 characters, you will get an Illegal Command returned, (ID ? CR). If you need to send 300 characters of data, send the first part, wait for the acknowledgement (ID CR), and then send the remaining part.

If you are using the @S command with a printer, you should have the *Protocol* parameter in the RF Terminal set to **XON/XOFF**. This will allow the RF Terminal to deal with the character buffer limitations of your particular printer. If you are using the O’Neil MicroFlash Printer, you must send a **NULL** character before the valid data to wake up the printer. See your printer manual for details and see **Chapter 6** for details on printer protocol.

If you are using a Cameo or Encore printer, you must have a RF Terminal that displays Z on the same line as the Frequency on the opening screen. If you don’t have a Z, the printer will not wake up. The Encore/Cameo printers wake up when their DSR line is raised; this takes a hardware modification on the RF Terminal which is no charge when specified at time of order; the cost to retrofit a unit for Cameo/Encore wake-up capability is the minimum repair charge, \$85. Call us for an RMA number, as the terminals must come back to us.

- Every statement must end with a data entry “prompt” command, whether the statement is a single command by itself or several commands combined together. Any illegal statement will be ignored as a command but will be displayed on the addressed RF Terminal display exactly as written. If no Terminal ID was included in the statement, it will try to display the invalid statement on ID 0. Once the ENTER key is pressed on the Terminal displaying the invalid statement, the terminal sends the Base Station a “?” character. The Base Station then in turn sends the message n?CR (where n is the Terminal ID and CR is a carriage return) back to the Host computer. RF Terminal software versions prior to 9.059 did not handle illegal statements the same way; for backwards compatibility, see the setup parameter for *Protocol* (change it to E).
- Prior to RF Terminal version 9075, the RF Terminal was available only with a 4 line display. The “Clear lines” command (@Cx) for the 4 line

displays differ slightly from the “Clear lines” command for the current 6 line displays.

The following table shows the programming differences that started with version 9075:

Command	Prior to 9075	9075 and after
@C0	Command did not exist	Clears all lines on both a 4 line display and a 6 line display.
@C5	Cleared all lines on a 4 line display	Clears line 5 on a 6 line display. Clears ALL lines on a 4 line display.
@C6	Command did not exist	Clears line 6 on a 6 line display. Will not affect a 4 line display

There are several other changes concerning the display in version 9075 and after:

- In order to use 6 line display terminals as 6 line terminals in an existing 4 line system, the Base Station must have firmware version DLx9075 or greater. If you try to use a 6 line terminal in 6 line mode on a Base Station with a version prior to DLx9075, the Base Station will send back an erroneous message:

**Base Reinitialized
Cycle Power on RF
Terminal and Sign-On**

- In order to maintain compatibility with 4 line display terminals in an existing system, there is a new option in the RF Terminal Setup for 6 line display terminals. The LCD DISPLAY MODE allows the user to configure a 6 line display terminal as a 4 line display (centering the data on the display and conforming to the old programming command format, i.e. @C05 clears all lines). See Installation and Setup for details on how to get into LCD DISPLAY MODE.
- The SIGN ON character for a 6 line display RF Terminal operating in 6 line display mode (see the previous point concerning LCD DISPLAY MODE) is different than for a 4 line display. Prior to 9075, all terminals signed on using ASCII 15. As of 9075, a 6 line display terminal operating in 6 line mode signs on using ASCII 22. If the 6 line terminal is configured for 4 line display, it signs on using ASCII 15, as do all terminals prior to version 9075. This allows you to use both types of display in the same system and be able to distinguish between the two terminal types. See page 6-6 for more information on SIGN ON.

CAUTION: All 6 line display terminals are by default, configured as 6 line display terminals and will try to SIGN ON using ASCII 22. **If you are trying to SIGN ON to an existing 4 line display terminal system that has not had any changes in its programming to utilize the 6 line display terminals, the 6 line display terminal will NOT BE ABLE TO SIGN ON.** Make sure to re-configure the Terminal using the LCD DISPLAY MODE to operate as a 4 line display terminal.

- 4 line display terminals can be upgraded to 6 line display terminals for \$150.00 per terminal. Call us for an RMA number, as the terminals must come back to us for the upgrade.

Here are some sample command statements utilizing some of the programming tips offered above:

@2,1,1,ENTER ITEM NO	Display ENTER ITEM NO on line 2, position 1 and wait for data input
@V23@1,2,1,WRONG ITEM	Play voice message 23, display WRONG ITEM on line1, position 2 and wait for data input
@C1@1,7,0,PICKING	Clear line 1. Display PICKING at position 7 of line 1. This command <i>by itself</i> is illegal . To be a valid statement, it must end with a data entry request. For example: @C1@1,7,0,PICKING@2,7,1,ITEM
@1,1,1,ITEM@2,1,1,QTY	Since only one command can be a "prompt" data entry request, this is an illegal statement and would be ignored as a command.

Base Station to Host Formats

The basic format of a message that is transmitted from Base to Host is fairly simple:

Byte position	Function	Possible values
1	RF Terminal ID	0-F
2+	Data Transmitted	**
Last	Termination of message	CR (ASCII 13)

Typically, the Base Station is sending the "answer" to the hosts "question" - for example, if a Base sent a host message to a terminal #2 that said:

2@1,1,1,ITEM NUMBER + EOT

The RF Terminal would display ITEM NUMBER on line 1, position 1 and accordingly, the operator would then enter an item number by scanning or using the keypad. The RF Terminal transmits the data entered -say it's **123** - to the Base Station, which in turn transmits the following to the host:

2123+CR

Where **2** is the Terminal ID, **123** is the data and **CR** is the termination.

Besides data, there are other messages that the Base Station will send to the Host:

Serial Reply

After a **Serial** command (@S) has been successfully completed, the Base Station sends to the Host the Terminal ID followed by a CR. Serial commands are typically used for attached serial printers. Serial commands cannot be combined with other commands in a message to the Base Station/Terminal. Remember, you can only send 247 characters (including the ID + @S + EOT).

SIGN ON

To login to the host computer, the user presses a key on the RF Terminal at power-up to get to the SIGN ON screen. As the user SIGNs ON, the Base Station sends back the following SIGN ON message to the host:

Byte position	Function	Possible values
1	RF Terminal ID	0-F
2+	SIGN ON	SI (ASCII 15) if 4 line display terminal or; if 6 line display terminal configured as 4 line display in firmware version 9075 or greater.
		SYN (ASCII 22) if 6 line display configured as a 6 line display in firmware version 9075 or greater
Last	Termination of message	CR (ASCII 13)

After a terminal SIGNs ON, the host should be prepared to acknowledge the SIGN ON and give the terminal instructions, such as:

***Standby for Assignment, Press ENTER to acknowledge
Nothing to do, Press ENTER and See Supervisor
Pick Item 1234***

If there is something for the Terminal to do, the host should send instruction to the terminal (as in "Pick Item 1234" above). If there is nothing to do at the time of SIGN ON, the host should acknowledge the SIGN ON and tell the terminal to *Stand By* or *See Supervisor* (see lines 1 and 2 above). You will notice that in lines 1 & 2 above, there is a request for the operator to press the ENTER key. This is required for the message to be a valid command - remember that all messages must end with a request for data input. The host should then expect a response from the terminal of **Terminal ID** + DATA (none if only pressing ENTER key) + **CR**.

SIGN ON is a good way for the terminal operator who has not received instruction from the host for several minutes to determine if he is still connected and if the host is still functioning. By SIGNing OUT and SIGNing back ON, the operator should receive a message that there is nothing to do. It is also a good idea for the

host to keep track of elapsed time that a terminal has not had a message sent out to it. The host should then send a message periodically to re-assure the operator (remember to ask him to press ENTER) that instruction is coming or tell him to see his supervisor for re-assignment (or whatever makes sense for your application).

Ideally, if the operator is leaving the area (to go to lunch or move to another building) before he is out of range of the network, he should SIGN OUT, then SIGN ON upon his return.

Prior to RF Terminal version 9075, all terminals signed on using ASCII 15. As of RF Terminal version 9075, in order to distinguish between 4 line and 6 line display terminals, an additional SIGN ON character was added. A 6 line display terminal configured as a 6 line display (see Installation and Setup for LCD DISPLAY MODE) now sends **ASCII 22** as its SIGN ON character. A 6 line display terminal configured as a 4 line display will transmit the ASCII 15 character for SIGN ON. All 4 line display terminals regardless of their version, will SIGN ON using the ASCII 15 character.

SIGN OUT

When a RF Terminal is powered down manually or the user presses the F1 key to exit data entry mode to go to one of the other modes (SETUP or ONE WAY), the host receives the following SIGN OUT message:

Byte position	Function	Possible values
1	RF Terminal ID	0-F
2+	SIGN OUT	SO (ASCII 14)
Last	Termination of message	CR (ASCII 13)

Base Station Error Feedback

The following are four different unexpected feedbacks that the Base Station can send back to your program: (Be sure to look for each of them to be sure your program doesn't blow up at an unexpected time.)

Addressing a Terminal not SIGNED ON

If the host attempts to send a message to a terminal that is not SIGNED ON, the Base Station sends back the following message to the host computer:

Byte position	Function	Possible values
1	RF Terminal ID	0-F
2+	Terminal NOT Signed In	DC1(ASCII 17)
Last	Termination of message	CR (ASCII 13)

The ASCII 17 character can be changed to ASCII 16 for XON/XOFF sensitive systems by changing the Base Station Setup. See **Chapter 2; RF System Setup** for details.

If the Base Station receives five **Addressing a Terminal not SIGNED On** messages in a row, it transmits the following message to the Terminal and shuts down: (it will recognize a reinitialize command (*@EOT) from the host though)

**Base Shut Down
Due to Host Logic
Error**

Check your program for the sequence error before starting again. The host program will have to reinitialize the Base Station or you will have to cycle power on the Base Station and have the Terminal Sign On again in order to continue.

Sequence Error Message

The one-for-one “host prompt/terminal response” protocol must be observed by the host program at all times. The host cannot send a second data entry prompt until it has received a response to the first data entry prompt. If it does, this is considered a **Sequence Error**. If the Base Station receives a command that is out of sequence, it sends the following message back to the host:

Byte position	Function	Possible values
1	RF Terminal ID	0-F
2+	Sequence Error	DC2 (ASCII 18)
Last	Termination of message	CR (ASCII 13)

If the Base Station receives 5 **Sequence Error**’s in a row, it transmits the following message to the Terminal and shuts down: (the only host command that it will receive is *@EOT)

**Base Shut Down
Due to Host Logic
Error**

Check your program for the sequence error before starting again. You will have to reinitialize the Base Station by host program control (*@EOT) or manually cycle power on the Base Station and have the Terminal Sign On again in order to continue.

Illegal Command

- When a terminal receives an illegal statement from the host, it will display the entire statement on the terminal. Once the ENTER key is pressed on the terminal, the terminal sends a “?” back to the Base Station.

Byte position	Function	Possible values
1	RF Terminal ID	0-F
2+	Illegal Command	?
Last	Termination of message	CR (ASCII 13)

For example, if Terminal #2 received an illegal command, the Base station would transmit to the host:

??CR

- If a command is sent from the host to the base station without a valid terminal ID character, such as:

@1,1,1,Scan Serial Number

since the command doesn't specify which terminal it is meant for, the base sends the following message back to the host:

***?CR**

Base Station Initialized Message

Whenever the Base Station is powered up, it sends a message back to the host as follows:

Byte position	Function	Possible values
1	BASE ID	* (<i>Base ID is fixed</i>)
2+	Base Initialization	DC3 (ASCII 19)
Last	Termination of message	CR (ASCII 13)

Since ASCII 19 is XOFF, the ASCII 19 character can be changed to ASCII 20 for XON/XOFF sensitive systems by changing the Base Station Setup. See **Chapter 2; RF System Setup** for details.

The **Base Station Initialized** message is provided so that the host will know that there has been a power interruption on the Base Station. When a serial device powers up, the first byte transmitted is often garbage. QBASIC handles the garbage character without incidence, but GWBASIC does not unless ON ERROR GOTO is used to trap the error. Be aware of this potential garbage-byte problem in your programming. To isolate and test for the problem, power up the Base *without* the serial cable connected. After you power the Base up, plug in the serial cable. You will *not* see the "**Base Initialized**" message but it should not matter when testing for the garbage data.

If a terminal is signed-on to the system, and the base station is re-initialized, the following message is sent to the terminal:

**Base Reinitialized X
Cycle Power on RF
Terminal and Sign-on
again to Restart_**

where **X** is either a **P** (base initialization was power-related) or **H** (base initialization was host-related). (If your Base Station has an eprom earlier and RFX9079D, only P will show.)

Control Keys for Possible Programming

There are some keys on the RF Terminal keypad that when pressed, can transmit special ASCII characters back to the host program. This feature might be used by a programmer to allow the operator to review transactions. **You can use these keys for special program functions, such as scrolling thru data, backing up steps, jumping, finishing a process, etc** The keys are as follows:

Key	Code transmitted to Host
UP ARROW key	FS (ASCII 28)
DOWN ARROW key	GS (ASCII 29)
LEFT ARROW key	RS (ASCII 30)
RIGHT ARROW key	US (ASCII 31)
BEGIN key	ETB (ASCII 23)
END key	CAN (ASCII 24)
SEARCH key	VT (ASCII 11)

The STATUS key is reserved to only display the Time and Date.

For these codes to be transmitted, there are a few rules to follow:

- They cannot be part of a multi-character data entry. In other words, they cannot be used in combination with other data. If another key has been pressed, these special keys are ignored. If you are using the SHIFTED character on one of the special keys, it is accepted as the shifted character.
- For these keys to be transmitted, they must be pressed individually and exclusively and **MUST** be followed by the ENTER key.

The ARROW keys can be used *without* pressing the ENTER key by using the **Arrow Keys Only** Terminal Setup parameter. See **Chapter 2; RF System Setup** for details.

LOW Level ASCII Sequences using a DLL

The DLL disk is included with every RF Terminal system. To install the program, run the INSTALL.EXE program from Windows Explorer. The program, **PromptCOM** comes in both 16 bit and 32 bit versions of a *Windows Dynamic Link Library* (DLL) that allows programmers to easily add the ability to send prompts and receive data from their RF Terminal via the RF Base Station or direct serial link.

The *Application Programming Interface* (API) for **PromptCOM** consists of the following functions:

InitComDLL	<i>Initializes the PromptCOM system</i>
CloseComDLL	<i>Shuts down the promptCOM system and frees resources without closing the parent application.</i>
Setup	<i>Setup is used to configure the COM port</i>
SendCommand	<i>This function both sends a command to the terminal with the given ID</i>
GetCommData	<i>This function returns the data entered at the remote unit for that prompt</i>
DataAvailable	<i>Use this function to check if there is data to process before calling GetCommData</i>

There are sample programs distributed on the diskette for Visual Basic, Access and Delphi. There is also a Visual Basic code example that does not require the DLL. Use the Help System as documentation and view the README file for the latest changes.

PromptCOM/ActiveX

Drop-in components are tools that are added to your programming environment "tool kit". There are a variety of different technologies around for implementing a drop-in component such as VBX (for Visual Basic) and VCL (for Delphi and C Builder) and COM (ActiveX). Only the ActiveX variety are widely compatible with almost all development environments.

PromptCOM/ActiveX is a drop in COM component that allow programmers to easily add the ability to send prompts to and receive data from their R/F Terminal via an RF Base Station. It is compatible with Visual Basic, Visual C++, Delphi, and most other 32-bit development platforms. See the help file for installation instructions.

Programming Considerations

Before making any method calls, make sure you :

- Set the COM port properties (device name, baud, parity, bits, flowcontrol) as desired. Make sure the port is closed (call **CloseDevice**) before making changes to any of the port settings.
- Call the **OpenDevice** method. This activates the COM port used by this instance of the **WDterm** control.
- Set the **ActiveTerminal** property to identify the terminal on which you desire to operate. You can change the **ActiveTerminal** at any time in order to direct commands to appropriate terminals.

Test For Good Communication

Implement an event handler for **OnTermBaseRegister** that causes a beep or displays a message when called. If communication between the host PC and the base station is good, your event handler will fire when your program is running and you power up an attached base station.

Multiple Base Stations

- For installations using multiple base stations attached to a single host PC (these were called "channels" in PromptCOM/DLL) simply add a **WDterm** control to your application for each base station.

Terminal Tracking

- Since you get one set of event handlers for each base station, you will need some scheme for keeping track of where each terminal (up to 16 per base station) is in its transaction sequence. One possible solution is to use a "state"variable for each terminal (perhaps stored in an array). Test the state variable to determine the next prompt for any given terminal. See the samples for more ideas.
- It is very important to keep track of "login status" for each terminal. Every **SignOut** event should have an associated **SignIn** event and a given terminal should not be allowed to **SignIn** twice without an intervening **SignOut**. Multiple **SignIns** from one terminal without appropriate **SignOuts** indicate either:
 1. A terminal going out of range and having its power cycled before returning within range OR
 2. Two (or more) terminals using the same ID (terminal ID conflict).

Concepts

When you use drop-in components in your program you will follow the standard object-oriented programming paradigm that uses properties, methods, and events to implement the functionality of the drop-in component.

- **Properties** are the various configuration variables used by the drop-in component. An example of a property is the **ComDeviceName** setting.
- **Methods** are function calls used to issue commands and access features of the drop-in component. An example of a method is sending an **Input** command to the terminal.
- **Events** are function definitions placed in your application's source code. The function definitions in your source code are called Event Handlers. The skeleton structure of the event handler's source code is automatically generated. The code in the Event Handler is called ("fired") by the drop-in component when a specific event occurs. An example of an event is when a terminal returns data and the **OnTermData** event is fired.

The details of how to access Properties/Methods/Events varies between development platforms. Details of how it works in some of the most popular platforms is illustrated in the samples included with the RF Utilities CD or available for download from our website at:

<http://www.barcodehq.com/wdterminal.exe>

Properties

Properties are the various configuration variables used by the **WDterm** control. They are directly assignable in your application (e.g. "**WDterm.ActiveTerminal = 5**") and can be set in your development environment's object browser.

Important: Except for **ActiveTerminal** and **Quiet**, all properties require the serial port to be "closed" before they can be changed. Use the **CloseDevice** method before setting properties and then call **OpenDevice** to re-open the serial port.

Note that your development environment may show more properties for the **WDterm** control than are listed here. This is normal. You may ignore properties you see that are not listed here.

ActiveTerminal

Valid values: *0 through 15*

Definition: This is the terminal ID (0-15) to which method call instructions are directed.

ComDeviceName

Valid values: *COM1-COM16*

Definition: This is the serial port that this instance of the control will use. If you have more than one base station, drop in another **WDterm** control and set its **ComDeviceName** for your other COM port(s).

ComBaudValue

Valid values: *300, 600, 1200, 2400, 4800, 9600, 19200*

Definition: This is the serial port speed setting and must match the base station setting.

ComParity

Valid values: *None, Even, Odd.*

Definition: This is a serial port setting and must match the base station setting. **WDterm** may allow other settings but those listed here are the only ones compatible with current version base stations.

ComDataBits

Valid values: *7, 8*

Definition: This is a serial port setting and must match the base station setting. **WDterm** may allow other settings but those listed here are the only ones compatible with current version base stations.

ComStopBits

Valid values: *1, 2*

Definition: This is a serial port setting and must match the base station setting. **WDterm** may allow other settings but those listed here are the only ones compatible with current version base stations.

FlowControl

Valid values: *None, XON/XOFF*

Definition: This is a serial port setting and must match the base station setting.

Quiet

Valid values: *True, False*

Definition: If **Quiet** is set to True then any status and error message generated by **WDterm** will be suppressed.

Methods

Methods are commands that you issue to the **WDterm** control. All of the "**Inputxxx**" commands cause the terminal to wait for operator input.

*Note that your development environment may show more available methods for the **WDterm** control than are listed here. This is normal. You may ignore methods you see that are not listed here.*

Important: When your application starts up, the serial port is "closed". You must call **OpenDevice** before other method calls will work.

Except for the **ReInitAll** method, all methods use the **ActiveTerminal** property to identify the terminal to use.

OpenDevice

Function: Opens the communications (serial) port. This must be called before any of the methods described below. Make sure to set all Properties as desired before calling this method (except **ActiveTerminal** or **Quiet**).

CloseDevice

Function: Closes the communications (serial) port. This must be called before changing any of the Property settings (except **ActiveTerminal** or **Quiet**). When your application starts up, the serial port is "closed". You must call **OpenDevice** before other method calls will work.

InputAny

Parameters: *line, position, prompt, shifted, timestamped*

Function: This instructs the **ActiveTerminal** to display the prompt at line and position and wait for data to be entered from either terminal keypad or scanner. If *shifted* is set to "true", the terminal will start in shifted mode. *Timestamped* appends a (hhmmss) prefix to the returned data.

InputKeyBd

Parameters: *line, position, prompt, shifted, timestamped*

Function: This instructs the **ActiveTerminal** to display the prompt at line and position and wait for data to be entered from the terminal keypad only. If *shifted* is set to "true", the terminal will start in shifted mode. *Timestamped* appends a (hhmmss) prefix to the returned data.

InputScanner

Parameters: *line, position, prompt, allowbreakout, timestamped*

Function: This instructs the **ActiveTerminal** to display the prompt at line and position and wait for data to be entered from the terminal scanner only. Setting *allowbreakout* to true allow

user to "break out" of scanner only mode by pressing the end key on the terminal. A termID+CR will be sent to the host.

InputYesNo

Parameters: *line, position, prompt*

Function: This instructs the **ActiveTerminal** to display the prompt at line and position and wait for a **Yes** (Enter key or C key) or a **No** (0 key or B key) from the terminal keypad.

Note: C and B keys are used to facilitate keypad entry while scanning with the integrated laser.

InputPassword

Parameters: *line, position, prompt, shifted*

Function: This instructs the **ActiveTerminal** to display the prompt at line and position and wait for data to be entered from the terminal keypad only. The entered data is not displayed on the terminal.

InputSerial

Parameters: *line, position, prompt*

Function: This instructs the **ActiveTerminal** to display the prompt at line and position and wait for data to be received through the terminal serial port. Waiting for serial input can be bypassed by pressing the enter key on the terminal which will send an empty data string to the host (fires the **OnTermData** event handler).

OutputSerial

Parameters: *data*

Function: This instructs the **ActiveTerminal** to send data to the terminal's serial port. Data must be less than 248 characters in length for each call to **OutputSerial**. If you are sending data to a printer attached to the terminal, make sure to set the Protocol parameter in the RF Terminal to XON/XOFF. See the RF Terminal Manual for details.

SendDisplay

Parameters: *line, position, prompt*

Function: This instructs the **ActiveTerminal** to display the prompt at line and position. Must be followed by an "**Input**" method call to take effect.

ClearScreen

Function: This instructs the **ActiveTerminal** to clear its display. Must be followed by an "**Input**" method call to take effect.

ClearLine

Parameters: *line*

Function: This instructs the **ActiveTerminal** to clear the specified line on its display. Must be followed by an **"Input"** method call to take effect.

SendDate

Parameters: *line*

Function: This instructs the **ActiveTerminal** to display date and time on the specified line number. Must be followed by an **"Input"** method call to take effect.

Beep

Parameters: *count*

Function: This instructs the **ActiveTerminal** to beep count times. Count may be a value from 1 to 9. Must be followed by an **"Input"** method call to take effect.

PlayVoice

Parameters: *msgnum*

Function: This instructs the **ActiveTerminal** to play voice message number *msgnum*. *Msgnum* may be a value from 1 to 99. Must be followed by an **"Input"** method call to take effect.

ReInit

Function: This instructs the **ActiveTerminal** to re-initialize. Must be followed by an **"Input"** method call to take effect.

NOTE: Base Stations using EEPROM versions prior to 9079 will cause the message "Base Reinitialized.." to be displayed on the terminal. Only the terminal has actually been re-initialized. Later Base Stations use the message "Buffer Reinitialized..." to indicate a single terminal re-initialization.

ReInitAll

Function: Instructs all attached terminals to re-initialize.

Events

Wdterm events occur when a specific condition is met. When an event is "fired", an event handler function in your application is called.

Though the details of exactly how it is done varies from one programming environment to the next, the source code skeletons for the various event handlers are automatically generated and inserted into your source code for you. See the samples for more specific information.

Each event passes relevant information to your event handler function. The only event that does not pass any data is **OnTermBaseRegister**. All others pass at least the Terminal ID on which the event occurred. **OnTermData** also passes the data that was keyed or scanned into the terminal.

Terminal ID is always passed as 0-15. A Terminal ID value of 99 indicates an error.

Once you have the event handler skeletons, you can proceed to add whatever functionality you desire to each event.

You must call the **OpenDevice** method before any events can be fired.

OnTermBaseRegister

Event: An attached base station has successfully powered up and communicated with the host computer via the serial connection.

OnTermSignIn6

Data passed: *terminal*

Event: A six-line terminal has signed in. Terminal ID is passed in terminal.

OnTermSignIn4

Data passed: *terminal*

Event: A four-line terminal has signed in. Terminal ID is passed in terminal.

OnTermSignOut

Data passed: *terminal*

Event: A terminal has signed out. Terminal ID is passed in terminal.

OnTermData

Data passed: *terminal, data*

Event: A terminal has sent data in response to an Input method call.

OnTermNotSignedIn

Data passed: *terminal*

Event: A command has been sent to a terminal that is not signed in.

OnTermSequenceError

Data passed: *terminal*

Event: The one-for-one host prompt/terminal response protocol has been violated. The host cannot send a second **Input** command until it has received a response from the first **Input** command. If a base station receives 5 sequence errors in a row, a Host Logic error is generated and the base shuts itself down.

While PromptCom/ActiveX will intercept and prevent most logic errors, they are still possible so you should implement this event handler!

OnTermIllegalCommand

Data passed: *terminal*

Event: An illegal command has been sent to a terminal.

PromptCom/ActiveX is designed to prevent illegal commands but software is not always perfect and we may not have imagined all the ways in which our customers will want to use it!

OnTermUpArrow

Data passed: *terminal*

Event: The up-arrow button has been pressed on a terminal. You must issue another **Input** method call before **WDterm** can respond to another keypress on the terminal.

OnTermDownArrow

Data passed: *terminal*

Event: The down-arrow button has been pressed on a terminal. You must issue another **Input** method call before **WDterm** can respond to another keypress on the terminal.

OnTermLeftArrow

Data passed: *terminal*

Event: The left-arrow button has been pressed on a terminal. You must issue another **Input** method call before **WDterm** can respond to another keypress on the terminal.

OnTermRightArrow

Data passed: *terminal*

Event: The right-arrow button has been pressed on a terminal. You must issue another **Input** method call before **WDterm** can respond to another keypress on the terminal.

OnTermBeginKey

Data passed: *terminal*

Event: The **BEGIN** button has been pressed on a terminal. You must issue another **Input** method call before **WDterm** can respond to another keypress on the terminal.

OnTermEndKey

Data Passed: *terminal*

Event: The END button has been pressed on a terminal. You must issue another **Input** method call before **WDterm** can respond to another keypress on the terminal.

OnTermSearchKey

Data passed: *terminal*

Event: The SEARCH button has been pressed on a terminal. You must issue another **Input** method call before **WDterm** can respond to another keypress on the terminal.

PromptNET TCP/IP Active X Controls

PromptNET/ActiveX is a drop in COM component that allows programmers to easily add the ability to send prompts to and receive data from their R/F Terminal via an RF Base Station across a TCP/IP network connection.

PromptNET requires a "Client" computer on a TCP/IP network (to which up to 4 serial Base Stations can be attached) and a "Server" computer visible on the network to the Client.

The client computer runs the **PromptNET** Client Utility program as a background task. The server computer runs your application which uses the **PromptNET** ActiveX component to communicate with the Client.

The ActiveX component is compatible with Visual Basic, Visual C++, Delphi, and most other 32-bit development platforms. The client program requires Windows 98 or later. See the help file for installation instructions.

Programming Considerations

Network Setup

- The network settings on both client and server must support TCP/IP communications.
- It is critical that the client and server computers are "visible" to each other across your network. Both computers must have an IP address in the same subnet. The server requires a static IP address while the Client can either have a static address or use an assigned IP address via a DHCP server or equivalent. Refer to your Windows networking administration utility in the Control Panel to configure computer IP address settings.
- **PromptNET** uses ports 54123 (server) and 54124 (client).
- You can link server and client through a dial-up or DSL internet link as long as the server has a static IP address and your router passes the above ports.

- If you are unsure of how to set up your IP configuration properly, refer to your network administrator for help.

Client Utility

- Make sure the Client Utility is properly installed on the client computer and communicating with at least one Base Station. Test the Client by cycling power on the Base Station. You should see a "Base SignOn" message in the monitor window.

Server Communications

- Run the Server Test Utility on the server computer. Now go to the client computer, set the IP address for the server computer and a unique "Base Name" for the Client Utility and attempt to connect to the Server Test Utility. If the Client Utility connects, you are configured properly. Go to the server computer, shut down the Server Test Utility and begin work on your **PromptNET** server application.
- For Client/Server communications, the Client Utility is required to be running on the PC that the serial Base Stations are attached to.
- Before making any **WDIPterm** method calls in your application, make sure to set the **ServerOn** property to "true".

Test For Good Communication

- Implement an event handler for **OnTermBaseRegister** that causes a beep or displays a message when called. If communication between the host PC and the base station is good, your event handler will fire when your program is running and you power up an attached base station.

Multiple Base Stations

- For installations using multiple base stations attached to a single client PC, simply use the four "channels" provided by the Client Utility program.

Terminal Tracking

- Since you get only one set of event handlers, you will need some scheme for keeping track of where each terminal (up to 16 per base station, up to 4 base stations per client) is in its transaction sequence. One possible solution is to use a "state" variable for each terminal (perhaps stored in an array). Test the state variable to determine the next prompt for any given terminal. See the samples for more ideas.
- It is very important to keep track of "login status" for each terminal. Every SignOut event should have an associated SignIn event and a given terminal should not be allowed to SignIn twice without an intervening SignOut. Multiple SignIns from one terminal without appropriate SignOuts indicate either:

1. A terminal going out of range and having its power cycled before returning within range OR
2. Two (or more) terminals using the same ID (terminal ID conflict).

Concepts

Drop-in components are tools that are added to your programming environment "tool kit". Only the ActiveX variety are widely compatible with almost all development environments. When you use drop-in components in your program you will follow the standard object-oriented programming paradigm that uses properties, methods, and events to implement the functionality of the drop-in component.

Properties are the various configuration variables used by the drop-in component. An example of a property is the **ServerOn** setting.

Methods are function calls used to issue commands and access features of the drop-in component. An example of a method is sending an **Input** command to the terminal.

Events are function definitions placed in your application's source code. The function definitions in your source code are called Event Handlers. The skeleton structure of the event handler's source code is automatically generated. The code in the Event Handler is called ("fired") by the drop-in component when a specific event occurs. An example of an event is when a terminal returns data and the **OnTermData** event is fired.

The details of how to access Properties/Methods/Events varies between development platforms. Details of how it works in some of the most popular platforms is illustrated in the samples included with the RF Utilities CD or available for download from our website at:

<http://www.barcodehq.com/wdterminal.exe>

Properties

Properties are the various configuration variables used by the **WDIPterm** control. They are directly assignable in your application (eg. "WDIPterm.ServerOn = true") and can be set in your development environment's object browser.

*Note that your development environment may show more properties for the **WDIPterm** control than are listed here. This is normal. You may ignore properties you see listed in your development environment that are not listed here.*

ServerOn

Valid values: *True, False*
Function: Set to *True* to enable the server. Set to *false* to turn the server off. You should leave this off unless your program is actually running. Setting it to *True* at design-time can cause problems.

Quiet

Valid values: *True, False*
Function: If **Quiet** is set to *True* then any status and error message generated by **WDIPterm** will be suppressed.

LogFile

Valid values: *blank or a valid file name*
Function: If the file does not exist it will be created. If it exists, it will be appended to. If **LogFile** is blank, no log file is maintained.

ClientList

Valid Values: *Read Only.*
Function: Returns a formatted string listing all attached client **BaseNames** and associated IP numbers. Format is "basename CR/LF ip address CR/LF basename...".

Methods

Methods are commands that you issue to the **WDIPterm** control. All of the "**Inputxxx**" commands cause the terminal to wait for operator input.

*Note that your development environment may show more available methods for the **WDIPterm** control than are listed here. This is normal. You may ignore methods you see that are not listed here.*

InputAny

Parameters: *basename, channel, terminal, line, position, prompt, shifted, timestamped*
Function: This instructs the terminal attached to client *basename* on channel to display the prompt at line and position and wait for data to be entered from either terminal keypad or

scanner. If *shifted* is set to "true", the terminal will start in shifted mode. *Timestamped* appends a (hhmmss) prefix to the returned data.

InputKeyBd

Parameters: *basename, channel, terminal, line, position, prompt, shifted, timestamped*

Function: This instructs the terminal attached to client *basename* on channel to display the prompt at line and position and wait for data to be entered from the terminal keypad only. If *shifted* is set to "true", the terminal will start in shifted mode. *Timestamped* appends a (hhmmss) prefix to the returned data..

InputScanner

Parameters: *basename, channel, terminal, line, position, prompt, allowbreakout, timestamped*

Function: This instructs the terminal attached to client *basename* on channel to display the prompt at line and position and wait for data to be entered from the terminal scanner only. Setting *allowbreakout* to true allow user to "breakout" of scanner only mode by pressing the end key on the terminal. A *termID+CR* will be sent to the host.

InputYesNo

Parameters: *basename, channel, terminal, line, position, prompt*

Function: This instructs the terminal attached to client *basename* on channel to display the prompt at line and position and wait for a Yes (Enter key or C key) or a No (0 key or B key) from the terminal keypad.

Note: C and B keys are used to facilitate keypad entry while scanning with the integrated laser.

InputPassword

Parameters: *basename, channel, terminal, line, position, prompt, shifted*

Function: This instructs the terminal attached to client *basename* on channel to display the prompt at line and position and wait for data to be entered from the terminal keypad only. The entered data is not displayed on the terminal.

InputSerial

Parameters: *basename, channel, terminal, line, position, prompt*

Function: This instructs the terminal attached to client *basename* on channel to display the prompt at line and position and wait for data to be received through the terminal serial port. Waiting for serial input can be bypassed by pressing the enter key on the terminal which will send an empty data string to the host (fires the **OnTermData** event handler).

OutputSerial

Parameters: *basename, channel, terminal, data*
Function: This instructs the terminal attached to client *basename* on channel to send data to the terminal's serial port. Data must be less than 248 characters in length for each call to **OutputSerial**. If you are sending data to a printer attached to the terminal, make sure to set the Protocol parameter in the RF Terminal to XON/XOFF. See the RF Terminal Manual for details.

SendDisplay

Parameters: *basename, channel, terminal, line, position, prompt*
Function: This instructs the terminal attached to client *basename* on channel to display the prompt at line and position. Must be followed by an **"Input"** method call to take effect.

ClearScreen

Parameters: *basename, channel, terminal*
Function: This instructs the terminal attached to client *basename* on *channel* to clear its display. Must be followed by an **"Input"** method call to take effect.

ClearLine

Parameters: *basename, channel, terminal, line*
Function: This instructs the terminal attached to client *basename* on *channel* to clear the specified line on its display. Must be followed by an **"Input"** method call to take effect.

SendDate

Parameters: *basename, channel, terminal, line*
Function: This instructs the terminal attached to client *basename* on *channel* to display date and time on the specified line number. Must be followed by an **"Input"** method call to take effect.

Beep

Parameters: *basename, channel, terminal, count*
Function: This instructs the terminal attached to client *basename* on *channel* to beep count times. Count may be a value from 1 to 9. Must be followed by an **"Input"** method call to take effect.

PlayVoice

Parameters: *basename, channel, terminal, msgnum*
Function: This instructs the terminal attached to client *basename* on *channel* to play voice message number *msgnum*. *Msgnum* may be a value from 1 to 99. Must be followed by an **"Input"** method call to take effect.

ReInit

Parameters: *basename, channel, terminal*

Function: This instructs the terminal attached to client *basename* on *channel* to re-initialize. Must be followed by an "Input" method call to take effect.

NOTE: Base Stations using EEPROM versions prior to 9079 will cause the message "Base Reinitialized..." to be displayed on the terminal. Only the terminal has actually been re-initialized. Later Base Stations use the message "Buffer Reinitialized..." to indicate a single terminal re-initialization.

ReInitAll

Parameters: *basename, channel*

Function: This instructs all terminals attached to client *basename* on *channel* to re-initialize.

TestClient

Parameters: *none*

Function: This instructs the Server to "ping" all attached clients. Results are recorded in the log.

Events

WDIPterm events occur when a specific condition is met. When an event is "fired", an event handler function in your application is called.

Though the details of exactly how it is done varies from one programming environment to the next, the source code skeletons for the various event handlers are automatically generated and inserted into your source code for you. See the samples for more specific information.

Each event passes relevant information to your event handler function.

OnTermData passes the data that was keyed or scanned into the terminal.

Terminal ID is always passed as 0-15. A terminal ID value of 99 is used as a placeholder for logging purposes.

Once you have the event handler skeletons, you can proceed to add whatever functionality you desire to each event.

You must set the **ServerOn** property to true before any events can be fired.

OnTermBaseRegister

Data passed: *basename, channel*

Event: A base station on client *basename* has successfully powered up on *channel* and communicated with the host computer via the serial connection.

OnTermSignIn6

Data passed: *basename, channel, terminal*
Event: A six-line terminal has signed in on *channel* at client *basename*. Terminal ID is passed in *terminal*.

OnTermSignIn4

Data passed: *basename, channel, terminal*
Event: A four-line terminal has signed in on *channel* at client *basename*. Terminal ID is passed in *terminal*.

OnTermSignOut

Data passed: *basename, channel, terminal*
Event: A terminal has signed out on *channel* at client *basename*. Terminal ID is passed in *terminal*.

OnTermData

Data passed: *basename, channel, terminal, data*
Event: A terminal on *channel* at client *basename* has sent *data* in response to an **Input** method call.

OnTermNotSignedIn

Data passed: *basename, channel, terminal*
Event: A command has been sent to a *terminal* that is not signed in.

OnTermSequenceError

Data passed: *basename, channel, terminal*
Event: The one-for-one host prompt/terminal response protocol has been violated. The host cannot send a second **Input** command until it has received a response from the first **Input** command. If a base station receives 5 sequence errors in a row, a Host Logic error is generated and the base shuts itself down.

*While **PromptNET/ActiveX** will intercept and prevent most logic errors, they are still possible so you should implement this event handler!*

OnTermIllegalCommand

Data passed: *basename, channel, terminal*
Event: An illegal command has been sent to a terminal.

PromptNET/ActiveX is designed to prevent illegal commands but we may not have imagined all the ways in which our customers will want to use it!

OnTermUpArrow

Data passed: *basename, channel, terminal*
Event: The up-arrow button has been pressed on a terminal. You must issue another **Input** method call before **WDIPterm** can respond to another keypress on this terminal.

OnTermDownArrow

Data passed:

basename, channel, terminal

Event:

The down-arrow button has been pressed on a terminal. You must issue another Input method call before **WDIPterm** can respond to another keypress on this terminal.

OnTermLeftArrow

Data passed:

basename, channel, terminal

Event:

The left-arrow button has been pressed on a terminal. You must issue another Input method call before **WDIPterm** can respond to another keypress on this terminal.

OnTermRightArrow

Data passed:

basename, channel, terminal

Event:

The right-arrow button has been pressed on a terminal. You must issue another Input method call before **WDIPterm** can respond to another keypress on this terminal.

OnTermBeginKey

Data passed:

basename, channel, terminal

Event:

The BEGIN button has been pressed on a terminal. You must issue another Input method call before **WDIPterm** can respond to another keypress on this terminal.

OnTermEndKey

Data passed:

basename, channel, terminal

Event:

The END button has been pressed on a terminal. You must issue another **Input** method call before **WDIPterm** can respond to another keypress on this terminal.

OnTermSearchKey

Data passed:

basename, channel, terminal

Event:

The SEARCH button has been pressed on a terminal. You must issue another **Input** method call before **WDIPterm** can respond to another keypress on this terminal.

Portable Printers

Cameo and Encore Common Information

Both of these printers are stocked by Worth Data for the convenience of our users who need portable printing.

These printers do **not** require any special protocol; they do not require the “wake-up byte” as do other printers. They do require a special cable that can be ordered from Worth Data (part #C12); cable pin-outs are available in **Appendix C: Cable Pin-outs**.

These printers require a hardware modification to the RF Terminal in order to work. You can determine if your Terminal is Cameo/Encore ready by looking at the third line on the opening screen where Frequency is displayed. It there is a **Z** to the right of the frequency number and display lines, your terminal is Zebra Cameo or Encore ready. If specified at the time of your RF Terminal order, there is no charge for the modification. The modification is available for RF Terminals you already own; the cost is \$85 because the RF Terminal must be returned to us for modification. Call us for an RMA number before sending it in.

Shipped with every Cameo or Encore printer ordered is a CD ROM with the Programmers Manual in PDF format and a label design program – *LabelVista*. This program allows you to design the program and create multiple format files that can be sent to the printer where they become resident in flash. Variable fields are defined and can then be filled in by the program when in operation.

Keep in mind the following information when using these versatile printers:

- The printer turn on (“Wake-up”) is accomplished by the RF Terminal toggling the DSR line on the printer, so only the @S command and the data you are sending to the printer is needed.
- Once the RF Terminal has turned on the printer, it stays on until the host program turns it off using the POWER OFF COMMAND “ESC(0x1b)p(0x70)” described in the **Printing Systems Programming Manual**, or until the automatic shut-down takes place (2 minute default).
- The 247 character limit applies to your command string. See your **Portable Printing Systems Programming Manual** for details on programming your printer.

Zebra Cameo Printer

The Zebra “Cameo ” Printers are portable direct thermal receipt printers, (**not** label printers – the Encore below prints labels). Bar codes can be printed on the receipts, but you can’t print labels.

One model of this printer is available with a magnetic stripe reader, allowing magnetic stripe input to the RF Terminal using the @R (serial input) command.

- The Cameo printer with magstripe input is capable of reading Track 1, Track 2 or Tracks 1&2. See your **Portable Printing Systems Programming Manual** for the correct character string to send in the @S command to turn on the magstripe reader. In order to receive magstripe input from the printer, you must then use the @R serial input command (see page 6-2 for details).
- When the Terminal sends data to the host, it sends it in the following format:

RF Terminal ID + DATA + CR

Typically, the data is simply a string of characters, but in the instance of data coming from the magstripe reader, there are some additional characters you need to be aware of. The magstripe reader sends its data in the following formats:

Track 1:

TRACK1 DATA + CR + LF

Track 2:

TRACK2 DATA + CR + LF

Track 1&2:

TRACK 1 DATA + CR + LR + TRACK 2 DATA + CR + LF

So, when the RF Terminal transmits the data to the host, it will be in the following format:

RF Terminal ID + TRACK 1 DATA + CR + LF + CR

RF Terminal ID + TRACK 2 DATA + CR + LF + CR

and

**RF Terminal ID + TRACK 1 DATA + CR + LF
+ TRACK 2 DATA + CR + LF + CR**

For some, the extra CR's and LF's will not pose a problem, but for others they may require you to do some additional programming in your host application. Again, see your **Printing Systems Pro-gramming Manual** on the CD ROM shipped with the printer.

Zebra Encore Printer

The Encore Printer is used for label printing. It doesn't have Magstripe input. The classic application is for printing shelf labels during shelf price verification:

- 1) The operator scans a shelf label.
- 2) The Terminal transmits scanned data to the host computer.

- 3) The host computer looks up the price, description, etc. and transmits the computer price back and sends the necessary commands to the attached Encore printer to prints a new shelf label with the correct price.
- 4) The terminal operator then peels off the label and applies it to the shelf.

Each printer is shipped with a no charge roll of thermal paper that can be used for development, including determining the exact label size that best fits you needs and the capabilities of the printer.

We stock the 2” and 3” Encore printers with several label sizes immediately available including:

Part Number	Description	Price/Roll
E2L1	2"x1" Vinyl Shelf Adhesive Labels	\$3.50
E2L2	2"x1.25" Paper Permanent Adhesive Labels	\$2.50
E2L3	2"x2" Paper Permanent Adhesive Labels	\$2.50
E2L4	2"x1.25" Vinyl Shelf Adhesive Labels	\$3.00
E3L1	3"x1" Vinyl Shelf Adhesive Labels	\$7.50
E3L2	3"x1.75" Paper Permanent Adhesive Labels	\$5.00

Shelf adhesive labels are designed for ease of removal to facilitate replacement. Permanent adhesive labels are designed to stick and stay stuck, making removal difficult without leaving a residue.

Chapter 7

Voice Message Operations

The RF Terminal's exclusive use of voice prompts allows you to overcome problems such as literacy, language and lighting. With proper planning, voice prompting can enhance your RF Terminal application, making it faster and simpler. Voice messages are recorded in the RF Terminal, and then triggered by a prompt from the host computer.

Why Use Voice Messages and Prompts?

- Voice messages can be in *any* language.
- The operator does not have to be able to read to perform some jobs.
- Audible instructions can be heard in poor lighting where it is difficult to read a LCD screen. MOST IMPORTANTLY, the data collection process is faster because the operator does not have to continually look at the screen for instructions. This is especially useful when you do not want or need to enter data from the keypad. Scanning bar coded numbers from a Quantity BARPAD can make keying unnecessary.

Voice messages and prompts are a good way to keep the operator's attention focused on the job at hand. Audible error messages and warnings also help to limit mistakes and downtime.

Tips for Using Voice Prompts

Over 90 voice messages can be recorded in the RF Terminal. Here are some tips on making your voice prompts user-friendly:

- Short messages are preferable for prompts; most English prompts can be stated in ½ second. Instead of saying, "Enter the Item Number," say "Item". The typical RF Terminal operator does not want to hear long messages thousands of times. Error messages are typically longer because they are the exception and need to provide more precise instruction to the user.
- **Record your voice prompts calmly.** A frantic sounding voice can become irritating, especially when heard repeatedly.
- **Speak clearly.** Correct pronunciation will make the voice prompts easier to follow for all users. Use common words that all users will understand.

- **Vary the tone of your voice for different prompts.** Using a different tone of voice or even a different voice for consecutive prompts or error messages will make it easier for the user to distinguish between them.
- **Be sure to record error messages for *all* possible problems** that the user may encounter during a session. Once the operator becomes accustomed to listening to the voice prompts, it may become easy to overlook a “display only” error message.

RF Terminal’s Voice Message Mapping

The RF Terminal is shipped with 75 seconds of total recording time. The time allotted for each message is partitioned as follows:

30 – ½ second messages (message numbers 01-30)

30 - 1 second messages (message numbers 31-60)

15 - 2 second messages (message numbers 61-75)

Messages are sequentially numbered beginning with the ½-second messages, followed by the 1-second messages, and finally the 2-second messages. You can change the partitions to allow for more or less of a particular length message. For example, if you decide you do not want *any* ½ second messages and you want 15 *more* 1-second messages, your allocation would look like this:

00 – ½ second messages

45 - 1 second messages (message numbers 01-45)

15 - 2 second messages (message numbers 46-60)

Voice message partitions are set in the RF Terminal either from the bar coded *Setup Menu* or by the keypad setup. From the Setup Menu, scan the bar code for “Voice Messages”, and then scan six digits. The first 2 digits correspond to the ½ second messages, the second 2 digits for the 1-second messages and the last 2 digits for the 2-second messages. See **Chapter 2; RF System Setup** for details on Terminal setup (by bar code setup menu *and* keypad). Remember that the total amount of time must add up to 75 seconds.

Programming Voice Messages

To record and playback messages or assign messages to error conditions, you have to get to SETUP MODE and enter the password. If you don't know how to do this, see **Chapter 2; RF System Setup** for details on how to get into the SETUP MODE. Once you have entered the password (OK, its WDTRI) you will see the following prompt:

R/F Terminal Setup->1
R/F Base Setup----->2
Voice Operations---->3

Press **3** to select **Voice Operations**. The next screen gives you your options:

Record/Playback--->1
Assign Errors----->2
Cloning Master----->3
Cloning Receiver-->4

Pressing the “1” key takes you into the voice recording and playback function. Pressing the “2” key allows you to assign voice message numbers to error conditions. “3” and “4” allow you to clone voice messages from one RF Terminal to another. Each option is shown in detail below:

Recording and Playback of Voice Messages

If you respond with a “1” at the menu, you will see the following Record/Playback prompt:

RECORD/PLAYBACK?
KEY [R/P]?

First, we will playback a message that has already been recorded. Let's use message #01 for this example. Press the **P** key (for Playback) to get to the next prompt:

KEY [R/P]?
MESSAGE #: _

At this prompt, enter a two digit number for the message number you want to listen to. Enter “01” and then press the **ENTER** key. You will probably hear the “ITEM” prompt recorded at the factory unless you have edited or reset the default messages. If you heard nothing, a new message can be safely recorded in the area assigned to message # 01. After you have heard the message (or static if no message has been recorded), the RF Terminal displays the RECORD/PLAYBACK prompt again:

RECORD/PLAYBACK?
KEY [R/P]?

To record a message, get out the microphone (no, it's not an earphone) shipped with the RF Terminal and plug it into the AUX jack located next to the POWER jack on the bottom of the RF Terminal. Answer the prompt by pressing the **R** key to record a message. The bottom line of the display now reads:

MESSAGE #: _

Enter the message number you are going to record. For this example, enter message **#03** (by default this is a blank message) by pressing **03**, then the **ENTER** key. The RF Terminal screen now shows:

**HIT ANY KEY TO
START RECORDING**

To record a message, press any key and hold it down. When you release the key, immediately start speaking into the microphone. To practice, let's record something in message **#03**. Get ready to say **ITEM** (in English or your language) into the microphone of the RF Terminal. When ready, press the **ENTER** key and the *instant* you release it, speak **ITEM** into the microphone. Remember to speak clearly – you have plenty of time to say **ITEM** in ½ second. When the message time is over, you will hear two beeps. The display is back to the **RECORD/PLAYBACK** prompt:

**RECORD/PLAYBACK?
KEY [R/P]?**

Now you're ready to listen to your first recording. Press the **P** key and key in **03** for the message number. Do not be discouraged if you didn't record the entire message. Our first attempt produced "EM" in a very frantic tone of voice. Practice speaking clearly and calmly (think of the poor guy who has to hear it 10,000 times next week) as soon as the key is released. You will get the hang of it with just a little practice.

That is the way all messages – prompts *and* errors - are recorded. If you are not sure which message numbers are blank, you can listen to messages until you find a blank for recording.

The host computer relies on the fact that the voice messages are stored in the RF Terminal itself and *not* generated by the host. The host computer will trigger the broadcast of a voice message by sending a prompt to the RF Terminal that tells it which message number to play. If the host thinks that message **#05** is **STOP** when it's really **GO**, it can cause confusion for the operator. That is why it is important to keep track of what messages are recorded where.

Assigning Error Messages

Error Messages are recorded the same way other messages are - by going into RECORD/PLAYBACK, selecting a message number and recording a voice message. The RF Terminal comes from the factory with some voice prompts and error messages pre-recorded. You can change any of these messages but keep in mind that the error conditions are hardware-related and that the voice error messages they are linked to are fixed. For example, the “**Low Batteries**” message is located at message #31. Whenever the RF Terminal detects very low batteries, it will play message #31, regardless of what is recorded there. You could record “Happy Birthday” and the RF Terminal would broadcast it any time it detected the low battery condition. To avoid confusion, try to keep the error messages somewhat related to the error condition they represent.

Default Voice Messages

Here are the default messages and the message numbers they are recorded under:

Message Recorded	Message #
Prompts	
ITEM	#01
QUANTITY	#02
Error messages	
LOW BATTERIES	#31
CHANGE BATTERIES	#32
TRANSMISSION FAILED	#33

Cloning Voice Messages and Setup from RF Terminal to RF Terminal

If you have several RF Terminals, you can record all of your voice messages in one RF Terminal and then simply “clone” them to your other RF Terminals. Cloning also copies the RF Terminal setup (except for Terminal ID).

You need 2 cables to clone RF Terminals; the **Data Cloning Cable #F38** and the **Voice Cloning Cable #T15**. The *Data Cloning Cable* plugs into the “Computer” port on each RF Terminal. This cable must be connected to clone properly.

One jack on the Voice Cloning Cable has two black rings on it – this end must plug in to the **RECEIVING** RF Terminal (the one you are transmitting to). Plug the single-banded jack end into the **MASTER** RF Terminal (the one you are going to record *from*).

Once both cables are plugged in to both Terminals, go to the Setup Menu on both Terminals. Select **3** for **Voice Operations** from the menu.

The “Receiving” RF Terminal must be started first. On the receiving Terminal, press the **4** key for **Cloning Receiver**. The “Receiving” unit will display:

Recv Setup/Voice
Please Wait_

Now you can start the “Master” RF Terminal by pressing the **3** key for **Cloning Master**. The “Master” Terminal will display:

Xmit Setup/Voice
Please Wait_

During the cloning process, you will hear the voice messages played aloud as they are copied. The process takes about 75 seconds to complete. After the Terminals are done cloning, they will both display:

End of Cloning
Hit Any Key_

If you did not hear the correct messages or you heard no messages at all, check your cables and receiver/master setup - **you may have transmitted from the wrong RF Terminal**.

DATA XMIT ERROR
CYCLE POWER

If you get the DATA XMIT ERROR message, you have to restart the whole cloning procedure.

Changing the Speaker Volume

The volume of the speaker can be increased significantly by adjusting a tiny potentiometer inside the RF Terminal. Changing the speaker volume also changes the headphone volume. The Headphone is an optional feature, Part #T12, and can be ordered with the RF Terminal or separately afterward. The #T12 Headphone also has a volume control built into the cable that will change only the Headphone volume. Because static discharge can cause damage to the RF Terminal’s circuit board, it is recommended that you use a ground strap or other grounding device when you are touching the inside of the RF Terminal.

To open the RF Terminal, turn the Terminal OFF and remove the four screws on the back (one in each corner). Lay the connected halves of the RF Terminal on a desk or flat surface. You now have access to the Flash RAM EPROM and several jumpers as well as the volume potentiometer.

Using the figure below, locate the volume control and make adjustments within the red lines marked on the potentiometer. Use a knife or a very fine blade flat

screwdriver to turn the volume control. Turn it **clockwise to increase volume** or **counter clockwise to decrease** the volume.

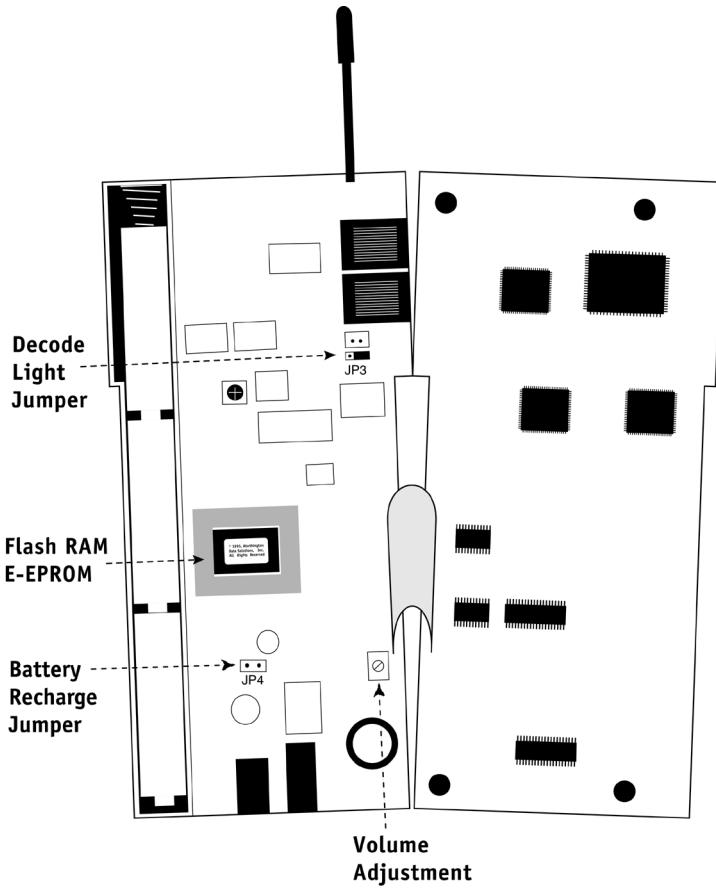

If you are in a noisy environment, try using the headphone that plugs into the AUX jack on the bottom of the RF Terminal. When using the headphone, you can conserve power by turning off the speaker. Go into the **SETUP MODE**, **Speaker Operations** and specify **1** for **Speaker OFF**. If using the #T12 Headphone, you can adjust the headphone volume independently using a volume switch built into the headphone cable.

Chapter 8

Troubleshooting

General Considerations

Site Test

The most basic tool for troubleshooting is the Site Test at 30 feet range. (See *Chapter 4* for the details on how to do a Site Test). If the Site Test fails at close range (30 feet), you have found the problem. The radio on either the Base Station or the RF Terminal is defective. If the site test works at 30 ft., but not at 50-100 feet, it could be interference from another radio source such as a 900 MHz phone. Take the Base and Terminal to another location to see if the site test still fails, (maybe home with you that evening).

If you have multiple terminals and multiple Base Stations, after site test failure, you can determine if the failure is with the Terminal or the Base by substitution. If you have only one Terminal and Base, you have no way of knowing which has failed; you must call us and get an RMA for both units to be checked out at the factory in Santa Cruz or in Ireland.

If the Site Test passes, there is nothing wrong with the radios.

Changing Batteries

For RF Terminals, the most frequent cause of problems is low batteries that have either been ignored or undetected. The real test for batteries is to remove batteries from a working unit and place them in a suspect unit. Don't assume that just because the batteries are new they are good. We have purchased "new" batteries off the shelf and tested them immediately to discover they are bad.

Most of the time batteries become the problem as a result of two failures:

- 1) The operator ignores the **Low Batteries** message and doesn't finish up the transaction and immediately change the batteries. If you turn the unit off and turn it on again, the batteries may have had time to "almost" recover. Unfortunately they will have so little reserve power that they will likely operate just long enough to produce some very screwy behavior on the RF Terminal. Intermittent laser beams, continuous beeping, black bars on the screen, etc. are just a few of the disastrous symptoms that can be exhibited.
- 2) NiCad or NiMH rechargeable batteries are being used, but the Terminal thinks that Alkalines are still being used. The Terminal ships with Alkaline batteries in the Setup. Alkalines and rechargeable batteries have different reserve powers, so the Terminal has to know if you have decided

to use rechargeables in order to properly notify you that the batteries have reached the low point requiring the batteries to be changed.

If you are using rechargeable batteries, you must change the **Speaker/Batteries** parameter in the **Terminal Setup** to reflect the usage of rechargeable batteries, otherwise you will strange behavior on the Terminal including: Intermittent laser beams, continuous beeping, black bars on the screen, etc. See **Chapter 2: Speaker Batteries** to change the setting. To display the remaining battery life of the AA batteries and the type of batteries the Terminal is expecting, press the **STATUS** key shows:

AAxBAT■■■■■■■■■■■-zz%

x=a when Alkaline batteries are specified in Speaker/Battery setup

x=n when NiMH or NiCad batteries specified in Speaker/Battery setup

Press the STATUS key again to resume processing.

Problems with a new installation:

If the Terminal displays the “**Waiting for Base to Acknowledge**” message, your radios are not communicating. Be sure they’re on the same frequency and then try a Site Test at close range. If the Site Test fails at 30 feet, one of the radios is dead. If you have multiple terminals, try another terminal. If the 2nd terminal also fails on the same frequency, the base station is bad. If the 2nd terminal passes the Site Test, the first terminal is bad.

If the Terminal displays the “**Waiting on Host Prompt**” message, the host program is not communicating with the Base Station. There is no radio problem, because the Base Station has already acknowledged the Terminal’s Sign In. The Terminal is waiting on the Host to tell it to do something. Try the demo program; if it works the problem is your program.

If the demo program fails, the problem is one of the following:

- 1) The cable between the Base Station and host computer is bad. Try the test with extension cables removed.
- 2) The host COM port is bad or assigned to another device driver installed. Try another COM port or try another computer.
- 3) RARELY !!!The RS232 chip (U101 location) on the Base Station is bad. If you have other Bases, swap these pluggable chips to see if the problem goes away.

Terminal Error Messages

Message	Meaning – Action Required
<i>”Waiting for Base to Acknowledge...?”</i>	Radios in Base and Terminal are not communicating. Be sure they are on same frequency. Do Site Test at 3 feet from Base. If Site Test fails, the problem is with Base or Terminal radio.
<i>”Waiting on Host Prompt”</i>	Problem is between Host computer and Base station. Check to see if host application is running. Check serial parameters and eliminate any extension cables. Run the Demo program. Try another COM port or another computer.
<i>”Base Station Shut Down Due to Host Logic Error, Cycle Terminal Power”</i>	<p>Problem is in host program. Notify programmer!</p> <p>If the Base Station receives 5 Sequence Errors in a row, it transmits the message to all terminals signed in and shuts down. Check your host program for the sequence error before starting up again. OR</p> <p>If the Base Station receives 5 messages addressed to a Terminal not Signed ON, it transmits this message to the all terminals signed in and shuts down.</p> <p>You will have to cycle power on the Base Station or you can send a command (*@EOT) form the host and have the Terminal Sign On again to continue. See Chapter 6, page 6-8 for more information on Sequence Errors.</p>
<i>” Base Reinitialized X Cycle Power on RF Terminal and Sign-on again to Restart_”</i>	<p>Base Station has been reinitialized. If message reads “Base Reinitialized P”, then reinitialization is due to a power problem. If “Base Reinitialized H” then the reinitialization was initiated by the host program. (if base is dlx9079 +). Fix problem (cycle power on Base or re-initialize from host program).</p> <p>This message is also occurs erroneously if you try to Sign On with a 6 line terminal in 6 line mode to a Base Station that is lower that DLx9075</p>
<i>” Buffer Reinitialized Cycle Power on RF Terminal and Sign-on again to Restart_”</i>	The host program has reinitialized the buffer in the Base Station for this terminal only. The Base is still operational and ready for you to power off your terminal, power on, and SIGN ON again. Other terminals are not affected.
LOW BATTERIES <i>Finish, Sign Off</i> Change Batteries	Finish the transaction you have started. The Press F1 to Sign Out. Then turn off the Terminal and change the batteries.
CHANGE BATTERIES UNIT SHUT DOWN	<p>The terminal will display this message for 20 seconds, sign out, and turn off.</p> <p>Change the batteries immediately. Don't let someone else pick it up and operate with partially recovered batteries</p>

Message	Meaning – Action Required
<i>Relay n Cannot be Heard by the Base Notify Supervisor</i>	The terminal has established contact with Relay Station x. Relay Station x has attempted to communicate with the Base Station through the 422 cabling with no success. Cable is bad.
<i>Transmission Failed To Retry, Move Closer And Press Enter</i>	The terminal has tried 10 times to get its message through to the Base Station with no success. Could be result of bad radio in base or terminal. Could be the operator has gone out of range of the base- if so, move closer and press any key. Could also be that there are too many terminals competing for radio time on one base station.
<i>Two Way Not Allowed Base in Other Mode Press <Enter> Key</i>	Sign On is not allowed if the Base is already in some other mode such as One-Way or Site-Testing, which was not properly concluded. Cycling power on base clears. Is another Base giving you this message?
<i>One Way Not Allowed Base in Other Mode Press <Enter> Key</i>	One-Way is not allowed if the Base is already in some other mode such as Two-Way or Site Testing which was not properly concluded. Cycling power on base clears.
<i>Site Testing Not Allowed, Base in Other Mode Press <Enter> Key</i>	Site Testing is not allowed if the Base is already in some other mode such as Two-Way or One-Way which was not properly concluded. Cycling power on base clears.
<i>Base is not Jumpered for Programming Cannot Setup Press <Enter> Key</i>	The Base must have JP103 set to P before it can be Setup through the Terminal. If Jumper is set correctly, there must be another base answering. Turn off the suspect base and try signing in again. If you get the same message, another base is on.
<i>Base is Jumpered For Programming Cannot Proceed Press <Enter> Key</i>	The Base jumper (JP103) is set to P for programming. Base jumper JP103 must be set to N for normal usage, (non-programming). If jumper is correctly set, there must be another base answering. Turn off suspect base and try again.
<i>No Firmware Detected 1 – Download Firmware 0 – Power off Terminal Press 0 or 1 now_</i>	The firmware has somehow been wiped out – probably from an interrupted firmware download. Press 1 to Download Firmware or press 0 to power off the terminal.

Two or more terminals with the same ID can generate all kinds of strange messages including those shaded above.

Two bases on the same frequency are big trouble.

Sometimes you get an error message and after checking, everything on the Base seems to be set OK. Drop power on the suspect Base and try signing in again. If you get the same message, there is another Base answering which should not be on the same frequency.

Troubleshooting specific problems

Communication Problems

I can't communicate at all...

- First, check the communication link from the Base Station to the host. Use the following command to test the transmission of data from host to Base and back again to the host:

@@*Edataaaaaaaaa<EOT>

where *dataaaaaaaaa* is any string of data, terminated by EOT. This string should be sent from the host to the Base Station. If the data is received by the Base, it echoes it back to the host in the format:

dataaaaaaaaa<CR>

where *dataaaaaaaaa* is the data string from the original transmission, terminated by a CR (ASCII 13). This test verifies communication in both directions (host to Base, Base to host).

- If the data isn't echoed back, either your host COM port or the Base Station has a problem. Check that the Base Station is **NOT** jumpered for Programming. JP103 should be set to **N**, (Normal), not P. If it is set to P, no communication from host to Base and back will take place.
- Once you know the Base Station is communicating with the host correctly, compare the frequency of the Base Station with the frequency of the Terminal. Use Site Testing to check the communication of the Terminal to the Base and back. Stay close, make sure no other Terminals are in use, and go to Site Test mode on the Terminal. You should get 96-100% on first try. If you don't, it's a good chance your radios need repair. Call Worth Data for an RMA.
- If you are using PICK or UNIX as your operating system, make sure the Base Station is set to "XON/XOFF Sensitive".

My response time is poor...

- First, do a Site Test right next to the Base Station. If it's not 98%, RF is the problem.
- Second, run one of the demo programs. If the demo runs fast, it is your program that is slow. If your program is not responding within 300ms, the Terminal has to send periodic messages, waiting for a response. A host program that takes 2 seconds to respond to a Terminal with a new prompt will increase radio traffic by 400% - greatly reducing the number of Terminals you can accommodate on one Base Station. See *Host Response Delay* in the Setup (**Chapter 2**) for help in avoiding this problem.

- If you have multiple terminals on one base and your Terminal firmware is not RFx9077J or higher, you should upgrade your firmware by downloading the latest off the website <http://www.barcodehq.com> on the downloads page. This will reduce contention between terminals by up to 50%.
- If you have good response time everywhere but on the outer fringe area, you may need a Relay.
- If you have several Terminals on one Base Station, consider adding another Base Station and splitting the Terminals to reduce contention. If you are running the RFDEMO program, the application response time is instantaneous, so any delays you see are due to radio traffic.

I'm not getting the distance I need...

To maximize range, the Base Stations and Relays should be located:

1. At the center of the area of intended coverage, and
2. As high as possible - mounted on the ceiling of a room with the antenna pointing downward works the best. Sometimes just raising the Base Station to 12 feet will dramatically increase the distance, especially in warehouses or grocery stores with tall shelving. A Base Station mounted on the wall with the antenna parallel to the floor is the worst position.

To accurately determine the hardware required to cover a particular area, you should use the Site Test mode built in-to the RF Terminal.

I can't communicate with the RS-232 port on my host CPU...

- This is one of the biggest problems called in. If you are not using our cables, check your cables first. If you have an extension cable, remove it for testing. If you have an extension cable of 80 feet or more attached to a Windows host, you need to be sure certain pins are not attached in the DB9 or DB25. See **Appendix C**; *RF Serial Pin-outs*.
- If you are using the PICK or UNIX operating systems, be sure you have set the Base Station to be "XON/XOFF Sensitive". You need to do this to prevent the XOFF code being sent as a "Base Initialization" message.
- Windows 95,98,2000,ME, NT; COM port setup should also be changed to turn off XON/XOFF. XON/XOFF is the default for Windows. You set these through the control panel, *System, Device Manager, Ports (COM & LPT), COM Port, Port Settings, Flow Control*. Set *Flow Control* to None.

RF Terminal Problems

The laser beam won't spread when I press the trigger, OR

My keypad is dead, OR

I get black bars on the display when I turn it on, OR

When I turn it on, it just beeps continually.

- Change to known good batteries, preferably out of a working unit and try again.

The unit won't power up with batteries (good batteries) but it will power using the Base Station power supply

- Your battery terminals inside the case may be corroded with battery acid or just contamination. Open up the case and clean the battery terminals with alcohol soaked cloth.

I get 6 beeps when the RF Terminal powers up...

- The unit needs repair. Call Worth Data for an RMA.

Problems reading Bar Codes

The reader won't beep when I try to read bar codes...

- Try reading a known good bar code - try the **1** on the Setup Menu bar pad table. Follow the steps for proper scanning technique discussed in **Appendix M; How to scan a bar code.**
- If using a wand scanner, try scanning at different speeds - a common error is to scan too slowly.
- Make sure the reader is configured to read the type of bar code you are trying to scan. Most bar code types are *disabled* by default and need to be enabled using the Setup Menu or keypad while in Setup Mode.

I get extra characters at the beginning or end of my bar code data...

- Clear the Preamble and Postamble settings.

I have very poor read rates when scanning bar codes...

- Carefully follow the scanning instructions in **Appendix M; How to scan a bar code** when reading any and all bar codes. As straightforward as scanning may seem, many people who call with a complaint about poor read rates simply aren't doing it right.

- Try reading the following bar code below as an example of a known “good” bar code. This bar code is a Code 39 bar code and is readable by the RF Terminal set to its default settings.

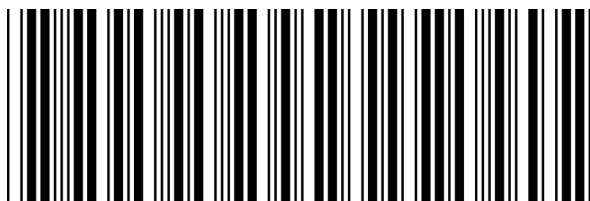

TEST LABEL

- Make sure *your* bar codes have clearly defined dark bars and clean white spaces. If the bars are so light that they are gray instead of black or are so dark that they “bleed” into the white spaces, the printing of the bar codes is the problem. Whoever is printing the bar codes needs to make the necessary corrections.
- The bar code should also have a “quiet zone” of at least ¼” to the left of the first bar and to the right of the last bar. Make sure to start your scanning to the left of the bar code in the “quiet zone”, moving the scanner quickly and smoothly as if drawing a line through the bar code. If using a laser scanner or CCD scanner, make sure the beam covers the bar code completely.
- Make sure you are using the correct type of scanner for the type of bar code you are reading. If you are using an *infrared* wand, your bar code must be printed using infrared-quality ink.
- If using a wand scanner, **clean the tip**. You would be *amazed* at how many wands we see where the only problem is that it needs to be cleaned. You would also be amazed at what we have found inside the tips of some of these wands. If using a laser or CCD, clean the window of the scanner with a soft cloth.

If you have a problem...

- **Save the shipping box.** If you ever need to send the RF Terminal or any of its’ parts back for repair, you will need the original shipping box.
- If you have a problem with your RF System, **consult the troubleshooting section of this manual FIRST.** If you cannot find the answer here, call your Dealer or Worth Data for help.

- Before you call your dealer or Worth Data for technical support, have your RF Terminal and related equipment in front of you and **be prepared to explain your problem in detail to the Technical Support Engineer.**
- The Engineer may ask you to go through some troubleshooting procedures while on the telephone. This will help them determine what is wrong and what the course of action should be. **Many problems can be resolved over the telephone and will not require that you return the equipment to us.** If you *do* need to return any of the RF equipment to Worth Data, the Engineer will issue an RMA number.
- If you do need to return the RF Terminal for ANY reason, **you MUST have an RMA number** first. Write the RMA number on the outside of the original shipping box and make sure to insure the shipment. All RMAs should be shipped back to the following address unless directed otherwise:

**RMA #XXXXXX
Worth Data Inc.
623 Swift St.
Santa Cruz, CA 95060
831-458-9938**

Frequency and Jumper Changes

Opening a Base or Relay

As preparation for changing the Base Station's frequency, baud rate, protocol, data bits, stop bits, and parity; or for changing a Relay Station's ID, frequency, or 422 termination, the case must be opened to expose the circuit board with the switches and jumpers. Be sure you disconnect power before starting.

Turn your Base or Relay Station upside-down, and unscrew its single phillips head screw. If you don't completely remove the screw, you can use it as a lever to pull up on the cover.

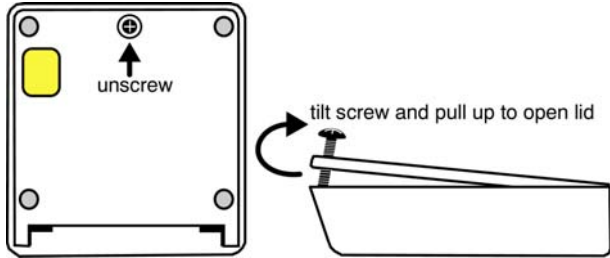

Otherwise, insert a fingernail, credit card edge or small screwdriver blade into the gap between the Base and side of the case, and gently use it as a lever to lift up the edge of the Base. Then grasp the edge of the Base and open it outward like a door. This exposes the reader's circuit board, as shown below.

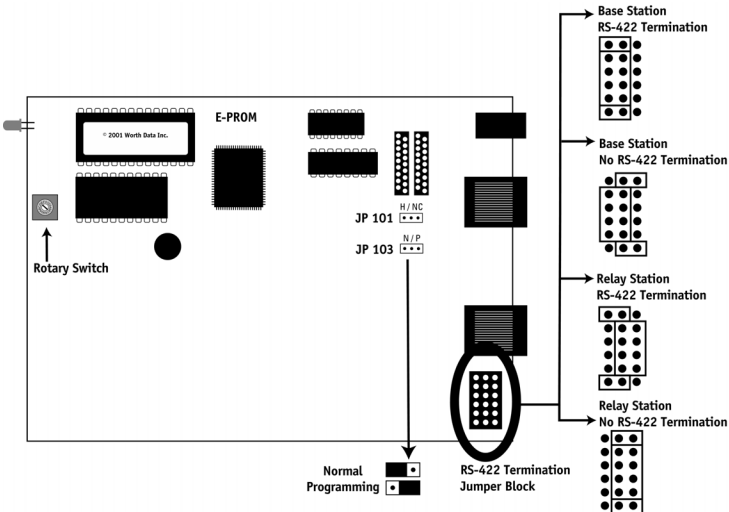

Jumper Changes

Refer to the circuit board diagram on page A-1 for reference.

- **JP103** controls the Programming Mode for the Base or Relay. For normal operation, leave this jumper in the Normal setting. To program the Relay ID or to program the Base Stations Computer Port settings from an R/F Terminal, move this jumper to P for Programming Mode.

If the Base Station is jumpered for Programming, the user will be unable to "SIGN ON" for communication and will see the following message displayed:

**BASE IS JUMPERED
FOR PROGRAMMING,
CANNOT SIGN ON
HIT ANY KEY**

If the Base Station is set for Normal, the user will be unable to setup the Base and will see the following message displayed:

**BASE IS NOT JUMPERED
FOR PROGRAMMING,
CANNOT SETUP
HIT ANY KEY**

After changing the N/P jumper (JP103), you must cycle power on the Base Station or Relay for the new setting to take effect. After cycling power, you can enter SETUP MODE on the R/F Terminal and make changes to the Base Setup from the R/F Terminal.

All changes to the Base Station must be made from the RF Terminal keypad only. This is to minimize confusion between setup of the R/F Terminal and the R/F Base Station.

Refer to Base Setup instructions in **Chapter 2; RF System Setup** for instructions on how to make the baud rate, parity, protocol, etc. changes to the Base Station.

RS-422 Termination Jumpers

Refer to the circuit board diagram on page A-1 for details.

The Base and Relay can be jumpered to be 422 terminated or not terminated. By default, all Base stations and Relay are shipped as terminated. Use the following guidelines to change the termination for your system:

- If the Base has multiple strings of relays radiating from it, the Base would **not** be terminated.
- If the Base is first in a string, (not in the middle or end of a string), set the 422 jumpers to **Base w/RS-422 termination**.
- The last Relay in each string should have its jumpers set as a **Relay w/RS-422 termination**.

Frequency Changes

To determine the current frequency of a Base Station or Relay, power up the Base or Relay and watch the LED light on the front of the unit. On power UP, a Base or Relay LED will blink "Frequency +3" times. For example, a unit that blinks **5** times on power up is operating on **frequency 2**. Frequency 0 blinks 3 times, frequency 5 blinks 8 times.

Changing the frequency on a Base or Relay

The Base Station and Relay must have their frequencies set to the same frequency as the R/F Terminals in their network. The frequency is set on a Base or Relay by turning a rotary switch to the setting 0-F (16 different frequencies to choose from). Jumper JP103 should be set to **Normal** when making this change. Use a very small flat head screwdriver to turn the switch to the desired number. See the circuit board diagram on page A-1 for location of the rotary switch

Setting the Relay ID

Each Relay must also have a unique ID, which is also set by turning the rotary switch, but is a little more complicated than setting the frequency:

- Move Jumper JP103 to **P** (for **Programming**)
- Move the Rotary Switch (SW1) to a position (0-F) to correspond to the ID to which you wish to set the Relay Station.
- Now cycle power on the Relay Station.
- Set JP103 back to **N** (for **normal**) and **restore the Rotary Switch to the frequency setting on which you intend operate the Base Station and Terminals in the network.**

Hardware changes on the RF Terminal

To change the Laser decode light operation or the speaker volume, the case of the R/F Terminal must be opened. Before opening up the R/F Terminal, be careful of static discharge to the board by grounding yourself (at least touch some large metal object) immediately before opening the case. To open up the R/F Terminal, unplug the power supply and turn the R/F Terminal OFF. Unscrew the four screws - there is one in each back corner. Lay the two halves of the R/F Terminal on a desk like the diagram below.

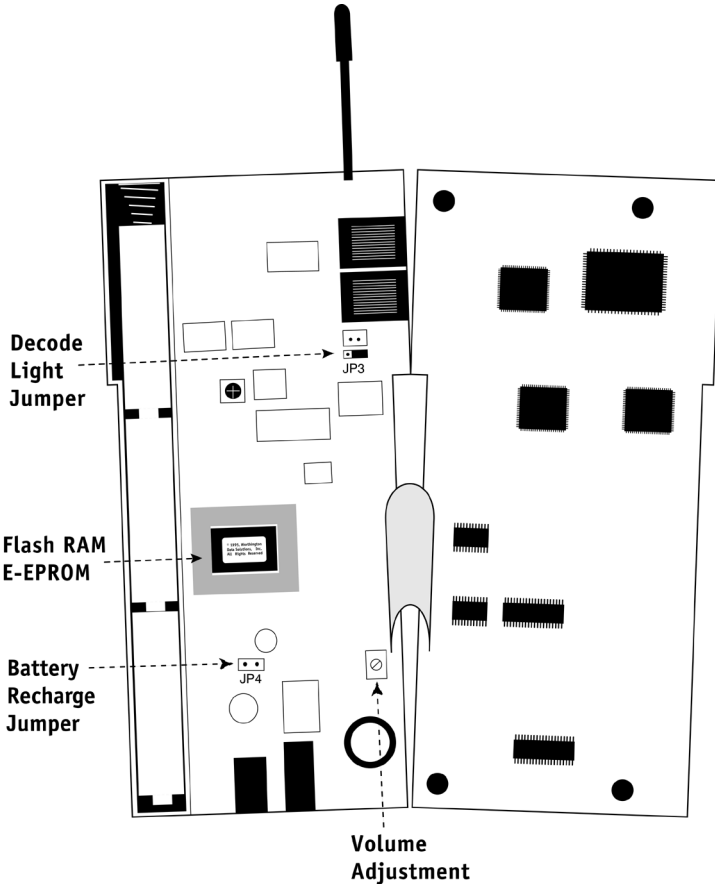

- **JP3** is the Laser Decode Light jumper. The RF Terminal is shipped with the decode light on the laser scanner deactivated so that the RF Terminal can operate interchangeably with a wand or laser. If you want to restrict the RF Terminal's operation to a laser scanner only and have the decode light *activated*, simply move the jumper JP3 from W to L.

- **JP4**, the Battery Recharge Jumper, exists on the LT71/T71 only, (the LT73/T73 is only recharging). This jumper's setting is determined by what type of batteries you plan to use in the R/F Terminal. Either **alkaline** (including Alkaline rechargeables), **Nickel Metal Hydride** rechargeable batteries or **NiCad** rechargeables may be used. If you are using rechargeable batteries, there is recharging circuitry built in to the R/F Terminal. To use the recharging circuitry, you must change jumper JP4, then plug in our F10 5v Power Adapter. The F10 Power Adapter is a separate item and must be ordered in addition to the R/F Terminal.

By default, the R/F Terminal is set up to use *regular* Alkaline batteries with the recharging circuitry OFF. *If you are going to use the recharging feature, be VERY CAREFUL to double-check the jumper setting. Plugging the power supply in when you have regular Alkaline batteries in the R/F Terminal but the jumper set for recharging can cause some serious damage. Only use rechargeable batteries (Alkaline, NiMH, NiCad) if using the recharging feature.* The jumper inside the R/F Terminal is located above the AUX jack and is labeled **JP4**.

The jumper must cover **BOTH** pins in order for the recharging to work. See the diagram of the R/F Terminal on the previous page for details on JP4's location. Recharging takes approximately 8 hours for a full charge if batteries are fully discharged first.

If you decide to use rechargeable batteries, be sure to change the setting in Speaker/Batteries to rechargeables to avoid many problems.

- The volume of the speaker can be increased or decreased in loudness by adjusting a tiny **potentiometer** inside the R/F Terminal. Locate the volume adjustment, (right next to the speaker jack) and make adjustments within the red lines marked on the potentiometer. Use a knife or a very fine blade flat screwdriver to turn the volume control. Turn it clockwise to increase volume. Turn it counter clockwise to decrease the volume.

If you are in a noisy environment, you may prefer the T12 Headphone, which plugs into the AUX jack on the bottom of the R/F Terminal. If using the headphone, you will probably want to turn off the speaker to conserve power. You can do this by entering the SETUP MODE and specifying **1** for Speaker OFF. You can control the Headphone volume independently by using the volume control built into the Headphone cable.

Adding Relays

Connecting a Relay Station

How it works...

A Relay station allows you to extend the area of your R/F coverage. Relays are connected by cable to the Base station, acting as a remote antenna. More than one Relay can be added by “multi-dropping” additional Relays. Using a Relay requires changing the setup on the Base station in addition to added cabling. The diagram below shows how Relays are added:

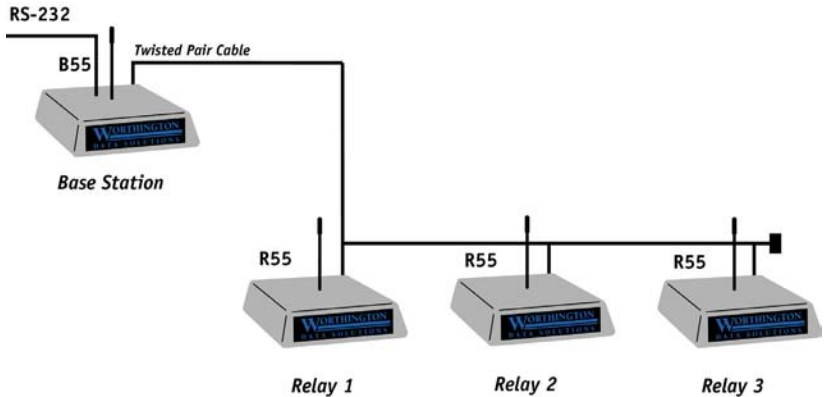

Although Relays will extend your R/F range, they do slightly slow down your response time. If response time is your problem, Relays may help *only* if the problem occurs on the *outer limits* of your range. Use **Site Testing** to help you determine if adding a Relay will help. If you are considering Relays, read **Chapter 4; Performance Issues** first.

If adding only one Relay, the cabling should run between the RELAY port on the Base station and the RELAY port on the Relay. In this example, both the Base Station and Relay should have jumpers set to “terminated”.

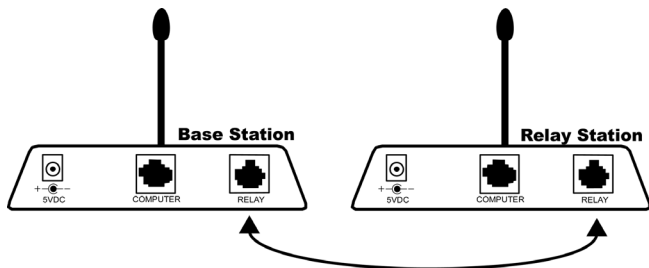

To add additional Relays, you must “multi-drop” them off a single bus line running from the RELAY port on the Base station. See the section below for cabling requirements and pin-outs. It is very important to follow the pin-out directions carefully and to use the suggested cable type. The majority of problems we see are the result of incorrect wiring.

Each Relay requires it’s own power supply. There is no serial parameter setup required on a Relay as it is transmitting only to the Base station and not directly to a serial port.

Routing the Wiring

The below diagram illustrates the **RIGHT** way to route your wiring and which units should be terminated. Notice this is the classical bus interface where the Base and Relays are connected to a “one-cable bus”. The bottom of the Y-Cables is connected into the unterminated base or relay(s). Notices that the two end units are terminated; the units in the middle are unterminated, including the Base in this example.

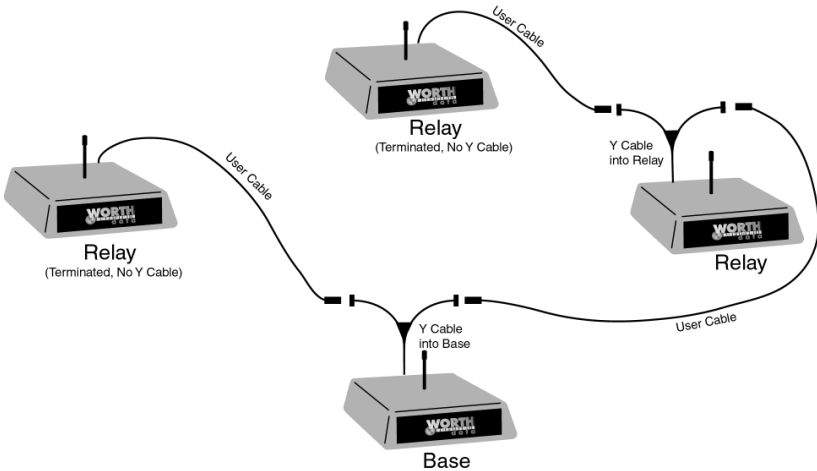

Correct Routing for Wiring

The below diagram illustrates the **WRONG** way to route your wiring and use the Y-cables. Sometimes people try to route everything through a panel or wiring closet – this will not work properly; it will generate excessive data noise and drag down the responsiveness of the Base and application. (With too much noise, the Base will stop working and issue a “Base Station Reinitialized” message to the terminals. If used, such a radial interface as below might appear to work most of the time, but it would be very sluggish and crash several times per day. Terminating or not terminating will be of no help. Do **Not** cable as below.

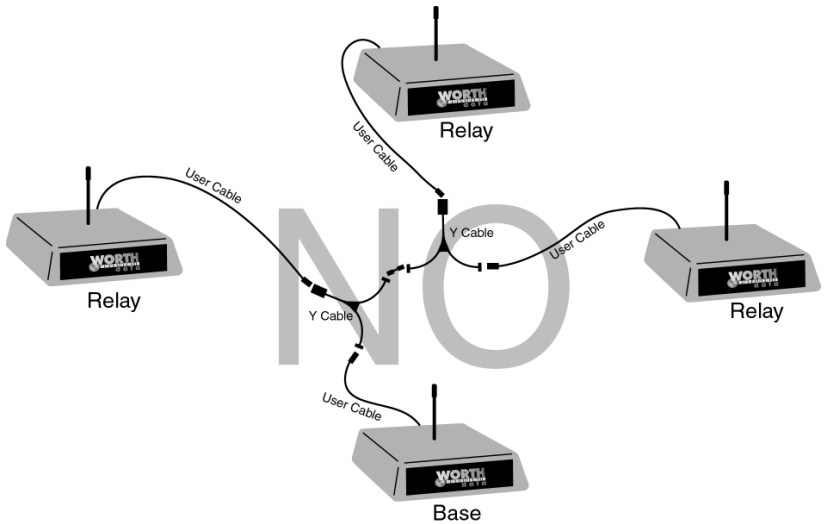

Incorrect Routing for Wiring

Relay Station RS422 Pin-outs

The **R/F Relay Stations** are connected by twisted pair wire -- use **Belden 1227A1, Cat 5 wire**, or equivalent. The *Relay Port* on the **Base Station** and the *Relay Port* on the **Relay Station** are connected with a straight cable using the following pin-outs:

Base Connector	Pin #	Relay Connector
Receive Data +	5	Transmit Data +
Receive Data -	6	Transmit Data -
Transmit Data +	2	Receive Data +
Transmit Data -	3	Receive Data -

Make a cable with 5-5, 6-6, 2-2, and 3-3 (a straight cable); but, be careful that you select wires so that the **2 wire is in the twisted pair with the 3 wire, and the 5 wire is in the twisted pair with the 6 wire.**

For all RJ Cable pin numbers, number from left to right with the metal pin side of the connector facing you and the cable running to the down position

Relay Test Plan and Failures

Relay Failure

Relay Station failures are often cable-related. If a Terminal puts out a “Who Can Hear Me?” message and a Relay that is for some reason *not* connected to the Base Station (bad cable, cut cable, broken connectors) hears it, it answers with the message:

**Relay n Cannot Be
Heard by the Base
Notify Supervisor
Press Any Key**

At this point, it is up to the operator to notify someone that the Relay is not communicating with the Base and to check the cabling *first*. There is no message sent to the host, so it is very important that the operator that receives this message notify someone immediately.

Because relay cabling is often troublesome, we supply a test cable for isolating the user-made cable from the process. This test cable is so short that it doesn't follow the rules of twists on the previous page – it is just a Ethernet patch cable for node, but adequate for testing the relay.

HINT: Use the suggested wire type, and if you're doing your own crimping, be sure to use the expensive metal crimpers (\$100) and not the cheap plastic

crimpers (\$15). Get someone familiar with making network (Ethernet) cables, but be sure to tell them **not** to use the Ethernet pin outs for the Relay Stations, (it has been tried more than once!).

Testing the Relay

To test communication with a Relay, first check out the radio by doing a Site Test on the offending Relay with all other Relays and Bases OFF. To check if a Relay is working with a Base Station, set the Base to a *different* frequency than the Relay and set the Terminal frequency to match the Relay frequency. Be sure to set RELAY=YES on the Terminal Setup. Then cable -connect the Relay to the Base (RELAY port to RELAY port).

Start your application on the host or use one of our demo programs provided with the Terminal (it's a good way to test) - it takes 10 or more seconds for the Terminal to switch to the Relay. The delay is a result of the Terminal having to put out a "who can hear me" message when it doesn't get a response from the Base Station. The Relay responds to the Terminal's "who can hear me" message and communication is established through the Relay. You will notice slightly slower throughput when working through the Relay.

Relay ID and Frequency...

Relays should be set to the same frequency as the Base station and R/F Terminals that you will be using in your system. Determining the current frequency is the same as on the Base station; power up the Relay and count the number of times the LED flashes (frequency + 3). The default setting is Frequency **0** (3 flashes). Each Relay also requires a unique Relay ID; the default ID is **0**.

To change the Relay ID or frequency, you must open the Relay case.

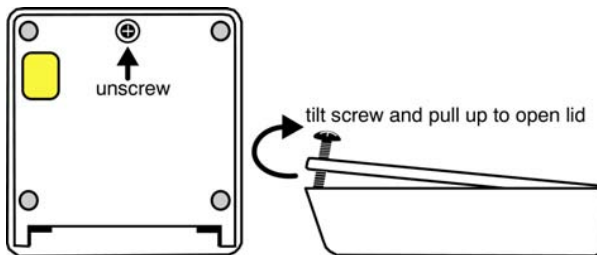

Changing the frequency on a Relay

The Relay must have their frequency set to the same frequency as the R/F Terminals in their network. The frequency is set on a Relay by turning a rotary switch to the setting 0-F (16 different frequencies to choose from). Jumper JP103 should be set to **Normal** when making this change. Use a very small flat head screwdriver to turn the switch to the desired number.

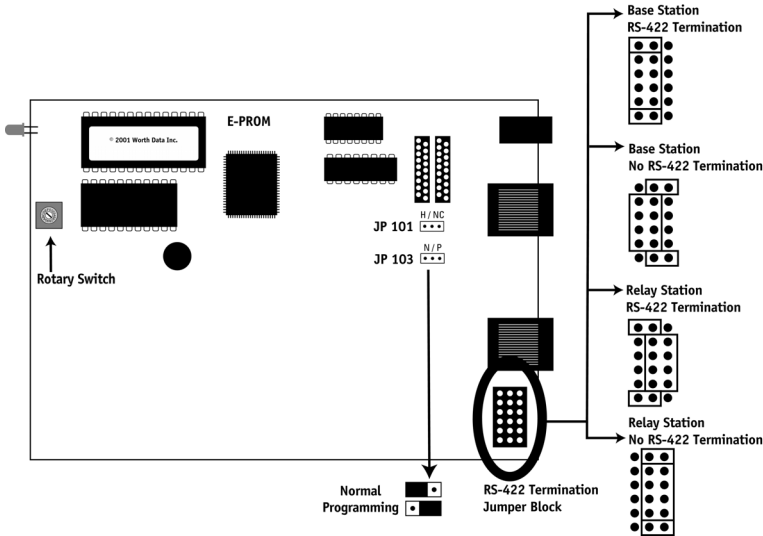

Setting the Relay ID

If you only have one relay, there is no need to set the Relay ID which is shipped default as relay 1.

If you have multiple relays, each relay must have a unique ID, which is also set by turning the rotary switch, but is a little more complicated than setting the frequency:

- Move Jumper JP103 to **P** (for **Programming**)
- Move the Rotary Switch (SW1) to a position (0-F) to correspond to the ID to which you wish to set the Relay Station.
- Now cycle power on the Relay Station.
- Set JP103 back to **N** (for **normal**) and **restore the Rotary Switch to the frequency setting on which you intend operate the Base Station and Terminals in the network.**

RS-422 Termination

When adding Relays to a system, the last Relay(s) in the line(s) must be terminated. By default, all Base stations and Relay are shipped as terminated. Use the following guidelines to change the termination for your system:

Refer to the circuit board diagram on the previous page for details.

- If the Base has multiple strings of relays radiating from it, the Base would **not** be terminated but each Relay would.
- If the Base is first in a string, (not in the middle or end of a string), set the 422 jumpers to **Base w/RS-422 termination**.
- The last Relay in each string should have its jumpers set as a **Relay w/RS-422 termination**. Any Relay that is *not* the last relay in the string would *not* be terminated.

Relay Station failures are often cable-related. If a Terminal puts out a “Who Can Hear Me?” message and a Relay that is for some reason *not* connected to the Base Station (bad cable, cut cable, broken connectors) hears it, it answers with the message:

**Relay *n* Cannot Be
Heard by the Base
Notify Supervisor
Press Any Key**

At this point, it is up to the operator to notify someone that the Relay is not communicating with the Base and to check the cabling *first*. There is no message sent to the host, so it is very important that the operator that receives this message notify someone immediately.

R/F Serial Pin-outs

Base Station to Host Pin-outs

The Base Station is connected to a PC with one of the following cables:

F34 DB25 Null Modem Cable

These are the pin-outs for Cable F34, a DB25 Female to 8 pin modular RJ45 with pins 2 and 3 crossed, used for a Base connected directly to a 25 pin male host serial port.

Mod 8 RJ45	Function	DB25 Female
1	Frame Ground	1
2	Transmit Data	3
3	Receive Data	2
4	Signal Ground	7

F34 Null Modem Cable

** Modular Pins 5-8 are connected to DB25 pins 5,6,8,4 but not used by the R/F Base.*

If you are planning to use a serial extension cable of 80 feet or more, you need to open the DB25 shell of our cable and be sure that only pins 1,3,2, and 7 are connected. All others should be cut. This is necessary to keep Windows from following noise transitions as handshaking transitions that can severely degrade the application or even crash Windows.

F36 DB9 Straight Cable

These are the pin-outs for Cable F36, a DB9 Female to 8 pin modular RJ45. This cable is used to connect the Base to a 9 pin Male host serial port.

Mod 8 RJ45	Function	DB 9 Female
1	Shell (chassis ground)	Shell
2	Transmit Data	2
3	Receive Data	3
4	Signal Ground	5

F36 9 pin cable

** Modular Pins 5-8 are connected to DB9 pins 8,6,4,7, but are not used by the R/F Base.*

If you are planning to use a serial extension cable of 80 feet or more, you need to open the DB9 shell of our cable and be sure that only pins 2,3 and 5 (plus the shell connection) are connected. All others should be cut. This is necessary to keep Windows from following noise transitions as hand-shaking transitions that can severely degrade the application or even crash Windows.

For all RJ Cable pin numbers, number from left to right with the metal pin side of the connector facing you and the cable running to the down position

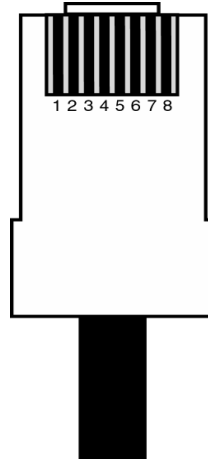

Relay Station RS422 Pin-outs

The **R/F Relay Stations** are connected by twisted pair wire -- use Belden 1227A1, Cat 5 wire or equivalent. The *Relay Port* on the **Base Station** and the *Relay Port* on the **Relay Station** are connected with a straight cable using the following pin-outs:

Base Connector	Pin #	Relay Connector
Receive Data +	5	Transmit Data +
Receive Data -	6	Transmit Data -
Transmit Data +	2	Receive Data +
Transmit Data -	3	Receive Data -

Make a cable with 5-5, 6-6, 2-2, and 3-3 (a straight cable); but, be careful that you select wires so that the 2 wire is in the twisted pair with the 3 wire, and the 5 wire is in the twisted pair with the 6 wire.

For all RJ Cable pin numbers, number from left to right with the metal pin side of the connector facing you and the cable running to the down position

Zebra Cameo/Encore Printers

These are the pin-outs for the cable needed to connect the Zebra Cameo Printer to a Worth Data R/F Terminal. You can order our **C12** cable for \$30, or if you already have a cable from Zebra and feel confident in your cable-making abilities, you can simply clip off the connector end that should connect to the RF Terminal (**not** the 8 pin din end) and replace the clipped-off connector with an RJ45 connector according to the pin-outs on the next page:

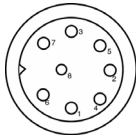

Cameo Connector



RJ45 connector for RF Terminal

Function	Printer 8 pin	RF Terminal RJ45	Function
Receive	1	2	Transmit
Transmit	2	3	Receive
CTS	3	not connected	none
RTS	4	7	CTS
Ground	5	4	Ground
DSR	7	8	DTR
DTR	8	not connected	none

Zebra Cameo - to - RF Terminal Pin-outs

Laser and CCD

The laser and CCD TTL pin-outs are:

Pin	Function
1	5 volts
2	Data
3	Phase
4	LED
5	Trigger
6	Enable
7	Shield(drain)
8	Ground

Laser and CCD Pin-outs

Remember:

*If you make your own cables, you are on your own. We accept **NO RESPONSIBILITY** for damages resulting from incorrect wiring.*

Firmware Upgrades

Base Station & Relay Firmware upgrades

Occasionally it is necessary to get firmware fixes for problems discovered with the *R/F Terminal System*, especially in the early stages of development. This is accomplished by replacing the existing EPROM chip on the board of the R/F Base Station or Relay with a new chip.

To replace the EPROM:

- Remove the cover to the *Base Station* or *Relay* (see Appendix A for diagrams and details)
- Remove the EPROM, (the chip with the Copyright label on it), by gently prying with a small flat head screwdriver, alternating ends to keep from bending the metal legs.
- Before inserting the new EPROM, notice that the EPROM has a small groove in one end; the end with the groove in it must match the groove in the socket that it is to be inserted into. Don't insert the chip backwards -- line up the groove in the chip to be on the same side as the socket's groove.
- You may need to slightly bend into the center the legs of the EPROM so that they can be inserted into the socket. Place the chip into the socket and begin to lightly push the chip into the socket. Unless you check, you may bend one of the leads not in a hole underneath the chip -- making your Reader dysfunctional. Once you are sure all legs are positioned into the holes correctly, you can push hard until the chip is firmly positioned into the socket.
- After turning the re-powering the R/F Base or Relay, you should see the LED flash the number of time equal to the frequency assigned. This indicates that the EPROM has been successfully installed. If it doesn't flash, remove the EPROM and check for bent legs. Also be certain you have not placed it in upside down, (not matching the notches).

R/F Terminal Firmware Upgrades

The R/F Terminal firmware can be upgraded by replacing the EPROM or by downloading new firmware into the R/F Terminal from your computer.

Replacing the EPROM (*Applies only to units shipped before 2003*)

The same procedure used to replace the EPROM on the R/F Base or Relay applies to the R/F Terminal also. Refer to **Appendix A**; *Frequency and Jumper changes* for instructions on opening the Terminal's case.

To replace the R/F Terminal EPROM:

- Open the R/F Terminal and locate the EPROM. The R/F Terminal EPROM is square and has a paper label on it for identification.
- To remove the EPROM, insert a paper clip leg at each corner with a groove in it, lifting up on the clip to pry out the EPROM.
- Notice that one corner is blunt. Put the new EPROM in the socket, lining up the blunt corner of the EPROM with the same blunt corner on the socket.
- Press it in, and put the case back together, replace the batteries and turn it on.
- If the first screen comes up correctly-- you're done. Otherwise, you probably didn't get it seated all the way in. Try again.

Downloading firmware from your computer

The RF Terminal firmware can also be upgraded by downloading a file with the current firmware into the RF Terminal's flash EPROM using the LOADER.EXE program or the RF Terminal EPROM Loader Windows program found on the R/F Terminal Utilities Disk.

If you have received a disk with the latest firmware or have downloaded the firmware from our website, **www.barcodehq.com**, download the firmware into the R/F Terminal using one of the following procedures:

Using Windows RF Terminal EPROM Loader

Start the R/F Terminal Loader program, then follow the directions on each screen. You can go back at any time by clicking the **BACK** button.



Step 1 requires you to choose a serial port to connect to.

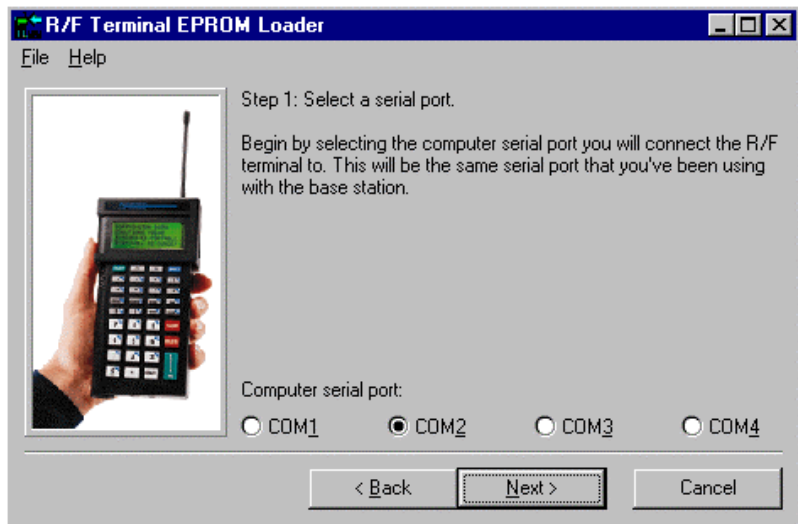

Step 2 requires you to select a firmware file name. The firmware available on our website is a self-extracting .exe file. Simply run the .exe file to extract the firmware file and enter the location and name of the file as shown below.

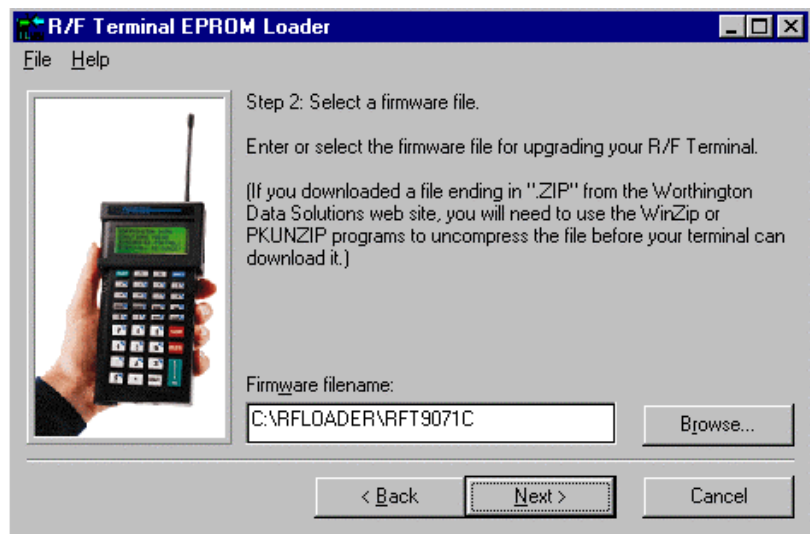

In Step 3, remove the base station from the serial cable and connect the R/F Terminal to the serial port using the same cable used to plug in the base station.

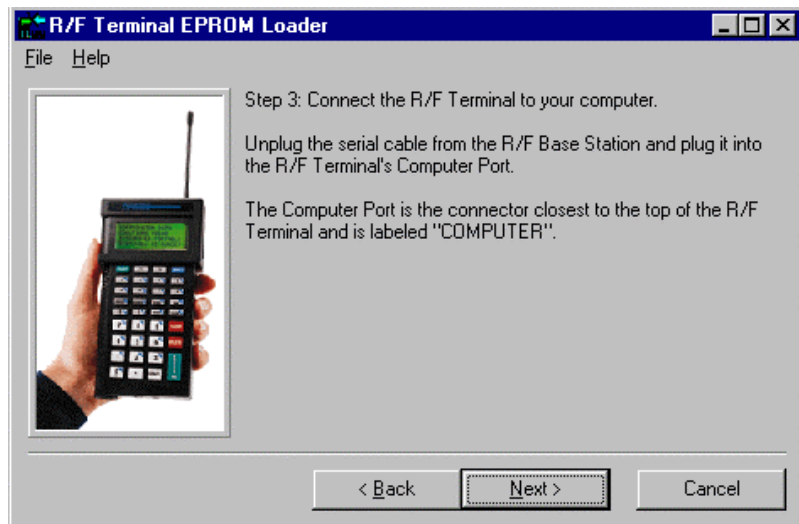

Step 4 involves preparing the R/F Terminal for the download. Turn on the R/F Terminal, then press any key to get to the SIGN ON? prompt. At the SIGN ON? prompt, press and release the **F1** key, then the **SHIFT** key, then the **D** key. This key sequence brings up the **RF Terminal Diagnostic Menu**.

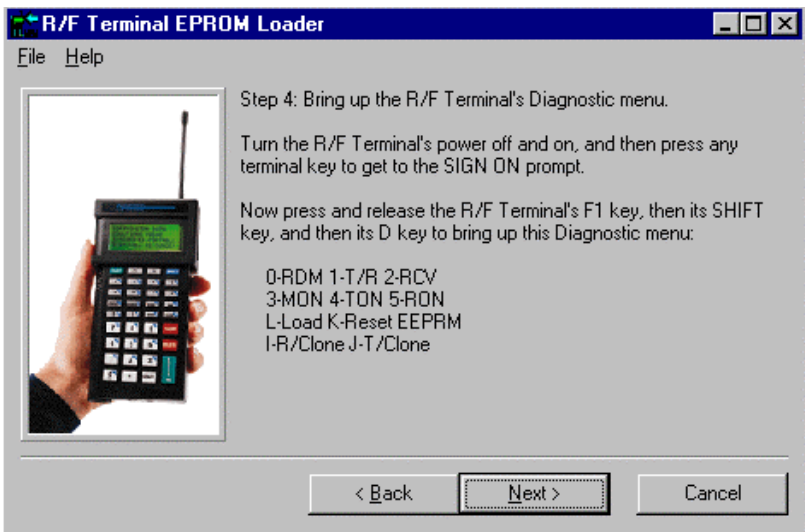

Once the Diagnostic Menu is displayed, press the **L** key (**END**) to prepare the R/F Terminal to receive the file. At this point, the R/F Terminal screen will not change.

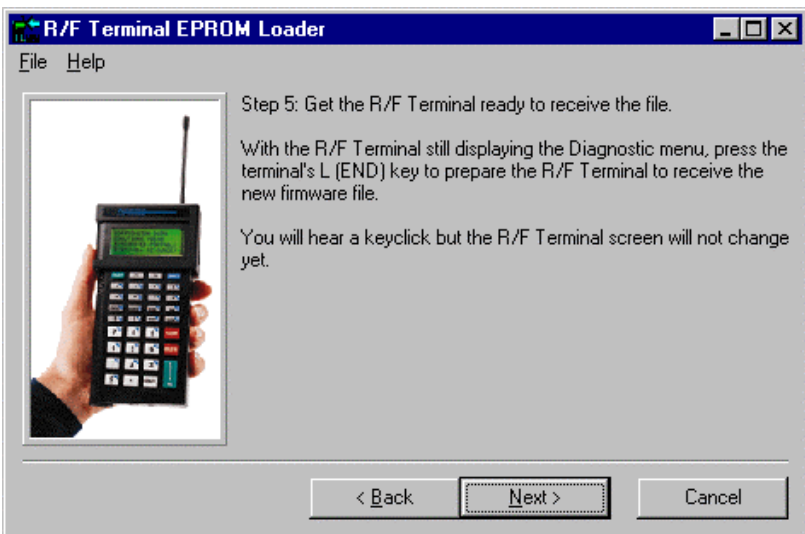

To begin the transmission in Step 6, click on . The status of the transfer displays on the screen as shown below.

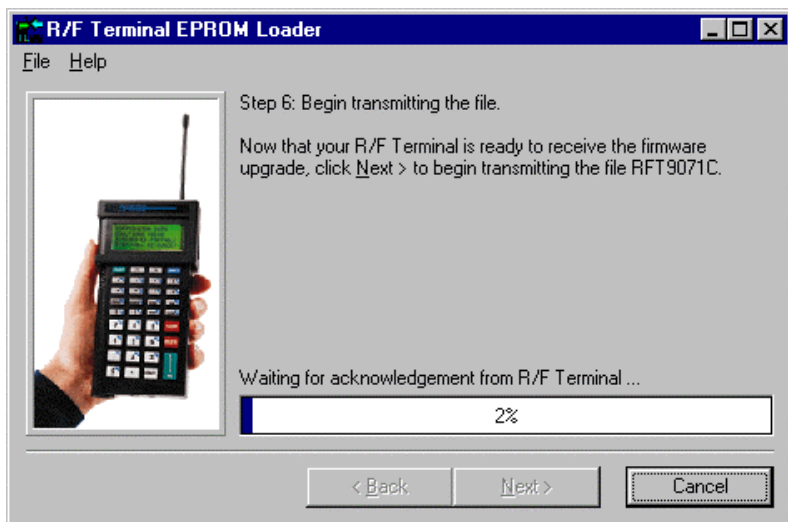

Once the transfer is finished, click on the **BACK** button to upgrade more R/F Terminals or click on **File**, then **Exit** to quit the program.

Appendix E

Code 39 Specifications

Code 39 (or Code 3 of 9) is the de facto standard of non-retail American industry. It is widely used in the automotive industry (AIAG specifications) as well as in government and military applications (LOGMARS specifications). Code 39 is flexible, features a large character set, variable data length and density, and bi-directional readability. Code 39 is extremely accurate; substitution errors are almost nonexistent. Its character set consists of numbers **0** through **9**, upper case **A-Z**, and characters *Space*, **\$**, **%**, **.** **/** **+** and **-**.

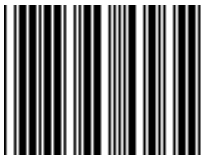

C39

The name "Code 39" comes from both the fact that its character set originally contained 39 characters (it now has 43) and from its structure. Each character is formed of three wide and six narrow elements, made up of five bars and four spaces. Code 39's density can vary from a low of .75 characters per inch (cpi) to a high of 9.4 cpi. There should be a ¼" "*quiet zone*" (white space) to the left and right of the bar code.

Code 39 uses an asterisk (*) as a start and stop character. This character must precede and follow the data in the bar code. The RF Terminal gives you the option of transmitting or not transmitting these characters when the bar code is read.

Exact specifications for Code 39 and other bar code symbologies can be obtained from ANSI at the address below:

American National Standards Institute
Customer Service
11 West 42nd St.
New York, NY 10036
<http://web.ansi.org>

document ANSI/AIM BC1-1995

Code 39 has several advanced features and functions that are discussed further in this appendix.

Code 39 Advanced Features and Functions

Mod 43 Check Character

Standard Code 39 can be printed with a "**Mod 43 Check Character**". This Mod 43 check character *cannot* be used with **Full ASCII Code 39**.

Assigning a value to each character in the data to be bar coded from the table as follows derives the check character:

Char	value	Char	value	Char	value	Char	value
0	0	B	11	M	22	X	33
1	1	C	12	N	23	Y	34
2	2	D	13	O	24	Z	35
3	3	E	14	P	25	-	36
4	4	F	15	Q	26	.	37
5	5	G	16	R	27	space	38
6	6	H	17	S	28	\$	39
7	7	I	18	T	29	/	40
8	8	J	19	U	30	+	41
9	9	K	20	V	31	%	42
A	10	L	21	W	32		

Mod 43 Check character calculation for Code 39

Here is an example to illustrate how the check character is calculated for bar code data of **123XYZ**:

1. Take the sum of the values assigned to each character:

$$\mathbf{1 + 2 + 3 + 33 + 34 + 35 = 108}$$

I *2* *3* *X* *Y* *Z*

2. Divide the sum by **43**: (thus the name modulus 43)

$$\mathbf{108/43 = 2 \text{ with a Remainder of } 22}$$

3. Find the character corresponding with the remainder.

M (value 22) is the CHECK CHARACTER

The data becomes **123XYZM**, with **M** added as the Mod-43 check character.

Full ASCII Extension to Code 39

"Full-ASCII Code 39" expands the Code 39 character set to include all 128 ASCII characters. Symbols 0-9, A-Z and punctuation characters are identical to their Code 39 representations. Lower-case letters, additional punctuation characters, and control characters are represented by sequences of *two Code 39* characters.

This table depicts the Full ASCII character set as a function of Code 39 characters:

ASCII	Code 39	ASCII	Code 39	ASCII	Code 39	ASCII	Code 39
NUL	%U	SP	Space	@	%V	'	%W
SOH	\$A	!	/A	A	A	a	+A
STX	\$B	"	/B	B	B	b	+B
ETX	\$C	#	/C	C	C	c	+C
EOT	\$D	\$	/D	D	D	d	+D
ENQ	\$E	%	/E	E	E	e	+E
ACK	\$F	&	/F	F	F	f	+F
BEL	\$G	'	/G	G	G	g	+G
BS	\$H	(/H	H	H	h	+H
HT	\$I)	/I	I	I	i	+I
LF	\$J	*	/J	J	J	j	+J
VT	\$K	+	/K	K	K	k	+K
FF	\$L	,	/L	L	L	l	+L
CR*	\$M	-	- or /M	M	M	m	+M
SO	\$N	.	. or /N	N	N	n	+N
SI	\$O	/	/O	O	O	o	+O
DLE	\$P	0	0 or /P	P	P	p	+P
DC1	\$Q	1	1 or /Q	Q	Q	q	+Q
DC2	\$R	2	2 or /R	R	R	r	+R
DC3	\$S	3	3 or /S	S	S	s	+S
DC4	\$T	4	4 or /T	T	T	t	+T
NAK	\$U	5	5 or /U	U	U	u	+U
SYN	\$V	6	6 or /V	V	V	v	+V
ETB	\$W	7	7 or /W	W	W	w	+W
CAN	\$X	8	8 or /X	X	X	x	+X
EM	\$Y	9	9 or /Y	Y	Y	y	+Y
SUB	\$Z	:	/Z	Z	Z	z	+Z
ESC	%A	;	%F	[%K	{	%P
FS	%B	<	%G	\	%L		%Q
GS	%C	=	%H]	%M	}	%R
RS	%D	>	%I	^	%N	~	%S
US	%E	?	%J	_	%O	DEL	%T, %X

Full ASCII Table

Accumulate Mode

Accumulate Mode is an option allowing the RF Terminal to accumulate multiple bar codes in its buffer, then transmit them to the computer as if they had been a single bar code. This is useful for entering quantities and other variable data.

Accumulate Mode works with Code 39, Code 93 and Code 128 only and can't be used with a check digit. When the RF Terminal reads a bar code with a **space as the first character**, it beeps and buffers the data without transmission. It continues to read and buffer bar codes (up to 40 characters) until it reads a bar code **without a leading space**. Once it reads this last bar code, the entire buffer (including that last code) is transmitted as one long bar code. A "double-minus" sign (--) bar code clears the buffer. The **ENTER** code on this Barpad is a Code 39 *Start/Stop Character* only.

Accumulate Mode must be turned on using the bar coded Setup Menu or by using the keypad. *Accumulate Mode* is located in the Code 39 parameters. Choose **4** to *Enable* or **5** to *Disable* this feature.

This numeric Code 39 "Barpad" illustrates ACCUMULATE Mode. Scan **5**, **3**, **8**, and **Enter**. The RF Terminal transmits a single message of "**538**".



0



1



2



3



4



5



6



7



8



9



Clear







Enter

Appendix F

Code 93 Specifications

Code 93 is variable length, continuous, bi-directional, compact code. Code 93 is an alphanumeric bar code which consists of *43 data characters* (**0-9,A-Z,\$/+%.- and Space**), *4 control characters*, and a *unique start/stop character*. The entire set of 128 ASCII characters is represented in Code 93 using combinations of *control characters* and *data characters*.

The control characters are , , , and . Pairing these control characters with normal data characters creates full ASCII 93. It is almost identical to the pairings for Code 39; Code 39 uses \$M to produce a

Carriage Return (ASCII 13) character -- Code 93 uses M to produce the Carriage Return.

Code 93's two built-in check digits greatly minimize the possibility of reader substitution errors. The bar code reader never transmits digits the check digits. Code 93's Start and Stop characters are also never transmitted.

If you have not decided which bar code type to use for your application and are considering using Code 93, while we agree that Code 93 is an excellent code, we believe that Code 128 is generally preferable because:

1. Code 93 **does not** have the numeric compression capability that 128 does, and
2. Code 93 requires pairings to make all Full ASCII characters while 128 does not.

Appendix G

Codabar Specifications

Codabar is widely used in libraries, blood banks, the cotton industry and transportation industries. Its' character set consists of numbers **0** through **9**, and punctuation characters **+**, **.**, **-**, **/**, **:** and **\$**. Symbols **a**, **b**, **c**, **d**, **t**, **n**, ***** and **e** are used as start and stop characters. Characters are constructed of four bars and three spaces.



Codabar is a numeric-only code, but different combinations of start and stop characters can be used to identify different types of labels. Codabar's variable data length and extremely low error rate make for a versatile bar code.

Codabar start/stop transmission

The Codabar section on the RF Terminal Setup Menu lets you determine whether Codabar start/stop characters are transmitted or not. If you are varying start/stop characters with different types of labels, you'll want to "**Enable Stop/Start character Transmission**". Start/stop character transmission can also be helpful if you want your program to differentiate between data coming from the RF Terminal and data coming from the keyboard. If neither of these situations apply, you'll probably want to disable it.

Appendix H

Code 128 Specifications

Code 128 is a very powerful bar code, combining an extensive character set and variable length with compactness and error checking. The character set contains all 128 ASCII characters with each character made up of three bars and three spaces. Each element (bar or space) varies from one to four units in width, totaling 11 units of width per character. Code 128 contains two levels of error checking:

- Each character is checked for internal parity, **and**
- The last character is a checksum.



Code 128 has three subsets, A, B and C. Subset A contains alphanumeric characters and unprintable control characters, subset B contains alphanumeric characters plus printable control characters and subset C contains only numeric characters and uses a 2-character encoding scheme to create a more compact bar code. Code 128 uses an internal Mod 103 check character that is not displayed by the bar code reader. Code 128 bar codes can be made up of only one subset or may be a combination of several.

The Code 39 features of **Accumulate Mode**, **Caps Lock ON** and **Caps lock OFF** also apply to Code 128.

UCC-128/ EAN-128

UCC-128/EAN-128 Code is a subset of Code 128 adopted by the UCC and EAN council's for use as a shipping label symbology. UCC/EAN-128 bar codes always start with a Function Code 1 character. In addition, a Function Code 1 character terminates all variable length fields unless they are the last field in the bar code.

The RF Terminal outputs the following for the special function codes and start sequences:

-]C1 Start C/Function Code 1
- ^] (GS) Function Code 1 as a variable string terminator

If **UCC/EAN 128** is *enabled*, the reader looks for the Start C/Function Code 1 to indicate a UCC/EAN 128 bar code.

The **UCC Serial Shipping Container Code** specification calls for a 19

digit UCC/EAN 128 code with an additional Mod 10 Check digit (20 digits in all). The Mod 10 Check digit is calculated the same as the *Interleaved 2 of 5* example in **Appendix D**. It is the data length as well as the MOD 10 check digit that distinguishes the *UCC Serial Shipping Container Code* from other UCC /EAN 128 bar codes.

Scanning the appropriate bar codes on the RF Terminal Setup Menu enables **UCC/EAN 128**; or you can use the keypad in the PROGRAMMING MODE “Change Setup” option. If UCC/EAN 128 is *enabled*, you will be able to read both standard Code 128 bar codes as well as the UCC/EAN 128 bar codes with the *Function 1* character and the Mod 10 check character.

(00) 1 0028028 300055004 6

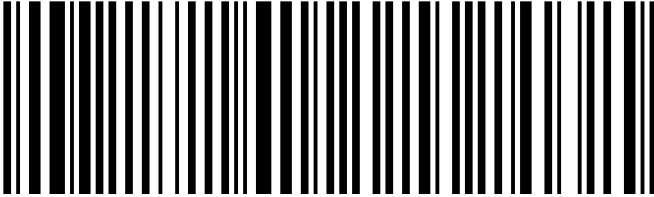

UCC-128 Shipping Container Code

If UCC/EAN-128 is enabled on the R/F Terminal reader, all Function 1 codes are transmitted as]C1. In addition, should you be reading a 20 digit Shipping Serial Container code, the Mod 10 check digit is also compared with the computed Mod 10 value to give further assurance of no substitutions. The UCC/EAN-128 Shipping Serial Container Code is a subset of UCC-128 or EAN-128 adopted for voluntary marking of shipping boxes with the exact serial number of the box, (used with EDI typically to identify a specific boxes contents. The code consists of the following format:

Start C	<i>not transmitted</i>
Function Code 1	<i>transmitted</i>
2 Digit Qualifier	<i>transmitted</i>
7 Digit Data Portion	<i>transmitted</i>
1 Digit Mod 10 Check Digit*	<i>transmitted-</i>
1 Digit Modulus 103	<i>not transmitted</i>
Stop Code	<i>not transmitted</i>

*Calculated using 19digits-UPC method

The UCC 128 specification is used extensively by the retail industry. If you have a requirement for a **UCC 128 Serial Shipping Container** bar code, be sure to follow the specification as closely as possible as many vendors will impose fines for non-conformance. For more information on UCC 128, contact the Uniform Code Council at:

Uniform Code Council, Inc.
7887 Washington Village Drive, Suite 300
Dayton, OH 45459
937-435-3870
937-435-7317
info@uc-council.org
8:00 a.m. to 6 p.m. EST

Many of the specifications are available online at:

<http://www.uc-council.org>

Appendix I

Interleaved 2 of 5 Code Specifications

Interleaved 2 of 5 Code is a numeric-only, even-number-of-digits bar code. It is widely used in warehouse and industrial applications. A combination of five elements, two wide and three narrow represent each character. Odd-number position digits are encoded in the bars, even-number positions in the spaces.



123456

Interleaved 2 of 5 Code is so susceptible to partial scans being interpreted as valid reads that we recommend at least one of the following safeguards:

- **Use one length of I 2 of 5 code.** Using one length of data allows you to tell the RF Terminal to look for one length of I 2 of 5 code only. By default, the RF Terminal is set to look for a 6 digit I 2 of 5 code but you can set the length to something different using the RF Terminal Setup Menu. Setting the length to **00** digits allows variable length bar codes scanning. If you must use the **00** setting, we recommend that you then use the “*Minimum/Maximum*” data length field when creating a program in the RF Terminal to check each field for the proper length.
- **Use a check digit.** Worth Data's **LabelRIGHT** printing program automatically calculates and prints a check digit upon request using the method below:

Interleaved 2 of 5 Mod 10 check digit calculation

1. Assume that the bar code data is **1987**.
2. Starting with the least significant digit (in this case, a 7), label the digits alternatively even and odd.

7 - even

8 - odd

9 - even

1 - odd

3. Take the sum of the odd digits:

$$8 + 1 = 9$$

4. Multiply the sum of the even digits by 3:

$$(7 + 9) \times 3 = 48$$

5. Add the results of steps 3 and 4:

$$9 + 48 = 57$$

6. Subtract the result of step 5 from the next highest multiple of 10:

$$60 - 57 = 3$$

7. The checksum becomes the low-order digit:

$$19873$$

8. Because the data now has an odd length, a leading zero is added, for the final result of

$$019873$$

UPC / EAN Specifications



UPC symbols are found on almost all grocery products and many other retail items. The UPC code most people are familiar with (UPC-A) is a fixed-length (12 digits) numeric only code, with the first digit controlled by UPC coding assignments and the last digit a checksum. UPC-E and UPC-E1 are variations of the standard UPC-A code. Each digit is constructed of two bars and two spaces. UPC has very precise standards of code size, structure, and numbers to be used.



EAN is an international superset of UPC. EAN-13 has 13 digits, with the first two digits representing a country code. The final digit is, as with UPC, a check digit. EAN-8 is a shorter version on the EAN-13 code containing seven data digits and ending again with a checksum.

The exact UPC/EAN symbol specifications are available from:

Uniform Code Council, Inc.
7887 Washington Village Drive, Suite 300
Dayton, OH 45459
937-435-3870

Specifications are also available via the internet at:

<http://www.uc-council.org>

Keep the following guidelines in mind when printing UPC bar codes:

- If you plan to use a "supermarket-type" in-counter scanner to read the codes, specify a bar code height of at least .9" for an optimal first read rate.
- Make it an early practice to observe the numbering conventions of the UPC Council. Do not label unmarked merchandise with a bar code whose numbers may conflict with those already assigned. If products with these numbers are not in your store now, they are likely to be in the future, causing conflicts in your inventory system.

- The leading **Number System Character**, (the first number of the 11 digits to be entered) should conform to these UPC assignments:
 - 0,6,7** Regular UPC 12 digit codes with numbers assigned by the UPC Council. (Do not use **0** as the leading number for in-store marking).
 - Store-marked random weight items of meat and produce.
 - Reserved for National Drug Code and Health Related Items.
 - Use this leading digit for in-store marking of non-food items.
 - Reserved for coupons. Do not use this today, or you will not be able to process coupons through your system tomorrow.

Supplemental codes



The UPC standards include the addition of a 2 or 5-character supplemental code as well as the Extended Coupon Code. To read the supplements, you must first enable them using the RF Terminal Setup Menu.

NOTE: *Enabling the supplements disallows the reading of UPC codes from right to left to assure that the 2 and 5 digit supplements are not get missed. Coupon codes can be read from right to left or left to right.*

ISBN Specifications

ISBN (International Standard Book Numbering) bar codes are essentially EAN-13 with a 5 digit supplement, where the first 3 digits are the Bookland country codes of **978** for books and **977** for periodicals. Although the bar code contains 18 characters, the ISBN format uses only 9 of them, along with a newly calculated Mod-11 check digit. For example, a bar code containing the numbers 978055337062153495 would transmit as 0553370626 in the ISBN format.

The RF Terminal has the option of transmitting in the ISBN format.



ISBN specifications are available from:

**American National Standards Institute
Customer Service
11 West 42nd St.
New York, NY 10036
<http://web.ansi.org>**

document ISO 2108:1992

The UPC/EAN checksum character

The last character in a UPC-A, UPC-E, UPC-E1, EAN-13 or EAN-8 bar code is the checksum. For reference, these are the methods of calculation:

Checksum calculation for UPC-A, EAN-13 and EAN-8

Use Worth Data's phone number (it's not a real UPC-A code) as sample data:

18314589938

Assign even and odd positions, starting at the right and moving left:

8 3 9 9 8 5 4 1 3 8 1
odd even odd even odd even odd even odd even odd

1. Starting with the leading digit, 8, take the sum of all the characters in the odd positions.

$$8 + 9 + 8 + 4 + 3 + 1 = 33$$

2. Multiply the result of step 1 by 3.

$$33 \times 3 = 99$$

3. Now take the sum of all the even-position characters.

$$3 + 9 + 5 + 1 + 8 = 26$$

4. Add the result in Step 2 to the result in Step 3.

$$99 + 26 = 125$$

5. Subtract the result from the next higher multiple of 10.

Next higher multiple of 10 over 125 = 130

$$130 - 125 = 5$$

5 is the *Modulo-10* check character. The data to be printed becomes:

183145899385.

This same formula is used for EAN-13 (using the 1-12 digits) and EAN-8 (using the 1-7 digits).

UPC-E Checksum Calculation

Use the sample data of 123456 to demonstrate the UPC-E checksum calculation:

1. The 6 digit UPC-E code is converted to a 10-digit code, using an expansion scheme based on the sixth digit:

If the code ends in:	UPC-E Data	Insertion Digits	Insertion Position	10 digit code
0	abcde 0	0000	3	ab 0000 cde
1	abcde 1	1000	3	ab 1000 cde
2	abcde 2	2000	3	ab 2000 cde
3	abcde 3	0000	4	abc 0000 de
4	abcde 4	0000	5	abcd 0000 e
5	abcde 5	0000	6	abcde 0000 5
6	abcde 6	0000	6	abcde 0000 6
7	abcde 7	0000	6	abcde 0000 7
8	abcde 8	0000	6	abcde 0000 8
9	abcde 9	0000	6	abcde 0000 9

Because the sample UPC-E code ends in a **6**, the insertion digits **0000** are inserted at the **sixth digit** (insertion position 6):

1234500006

2. Add the **Number System Character** of 0 to the sample data:

01234500006

3. Use the UPC-A check digit calculation described in the previous section to produce a check digit as if it were a UPC-A code. The check digit for the sample data is:

5

4. The complete 8 digit code consists of the *Number System Character*, the *original 6 digit code* and the *check digit*:

01234565

Appendix K

MSI/Plessey Specifications

Plessey is a variable length numeric only bar code. **MSI Bar Code** is a variable length, numeric-only code with an automatically appended Modulus 10 check digit. MSI is sometimes called *Modified Plessey Code*. If the user specifies an additional check digit, the MSI code can be 14 digits long, otherwise it has a maximum length of 13 characters. This is how the MSI check digit(s) are calculated:

The MSI **Mod 10** check digit is calculated as follows:

The example bar code data is:
82345

1. Form a number from the odd positions, starting in the units position.

835

2. Multiply the new number by 2

$$(835) \times 2 = 1670$$

3. Add the digits of product

$$1 + 6 + 7 + 0 = 14$$

4. Add the even digits of the original number to the result in 3

$$2 + 4 + 14 = 20$$

5. Subtract the result from the next highest multiple of 10

$$20 - 20 = 0$$

6. New Check Digit

0

7. Data with check digit is:

823450

The MSI **Mod 11** check digit is calculated as follows:

The example bar code data is:

943457842

1. Assign a checking factor to each number, starting with the units position of the number (in this example, the **2**) up to the highest order position (the **9**). Use checking factors of:

2,3,4,5,6,7,2,3,4,5,6,7...

2. Multiply the checking factor with its assigned number and add the products:

$$4 + 12 + 32 + 35 + 30 + 28 + 6 + 12 + 36 = 195$$

3. Divide the sum by 11

$$195/11 = 17 \text{ remainder } 8$$

4. Subtract remainder from 11

$$11 - 8 = 3$$

5. New Check Digit

3

(If the remainder is 10, no check digit is added.)

6. Data with check digit is:

943457823

Appendix L

Piggyback Laser Installation

The RF Terminal can use a hand-held Laser scanner (such as the LZ100, LZ200 and Symbol 3200 models) in what we call a "Piggyback" configuration. This configuration has the RF Terminal connected to the laser with a short cable and velcro strips to secure the RF Terminal to the top of the laser. This creates an all-in-one RF Terminal/Laser scanner.

Follow these steps to complete the Piggyback installation:

1. If the normal long coiled laser cable is still plugged into the LZx00 laser, use a pencil or flat head screwdriver to depress the tab on the RJ45 connector of the cable at the base of the laser scanner. Pull out the cable while depressing the tab.
2. Insert the untagged end of the T24 Piggyback cable into the laser. This cable is considerably shorter than the original laser cable.
3. Place the velcro strips on the top of the laser and the back of the RF Terminal separately according to the diagram below. Firmly press on the velcro surface to be sure the sticky back makes complete contact with the surface of the laser and RF Terminal.
4. Plug the tagged end of the T24 Piggyback cable into the RF Terminal SCANNER port.

A carrying case, the **T47** is available for this configuration. It is a one piece carrying case designed to help stabilize and protect the RF Terminal and Laser. See **Appendix N; *Optional Features*** for greater detail.

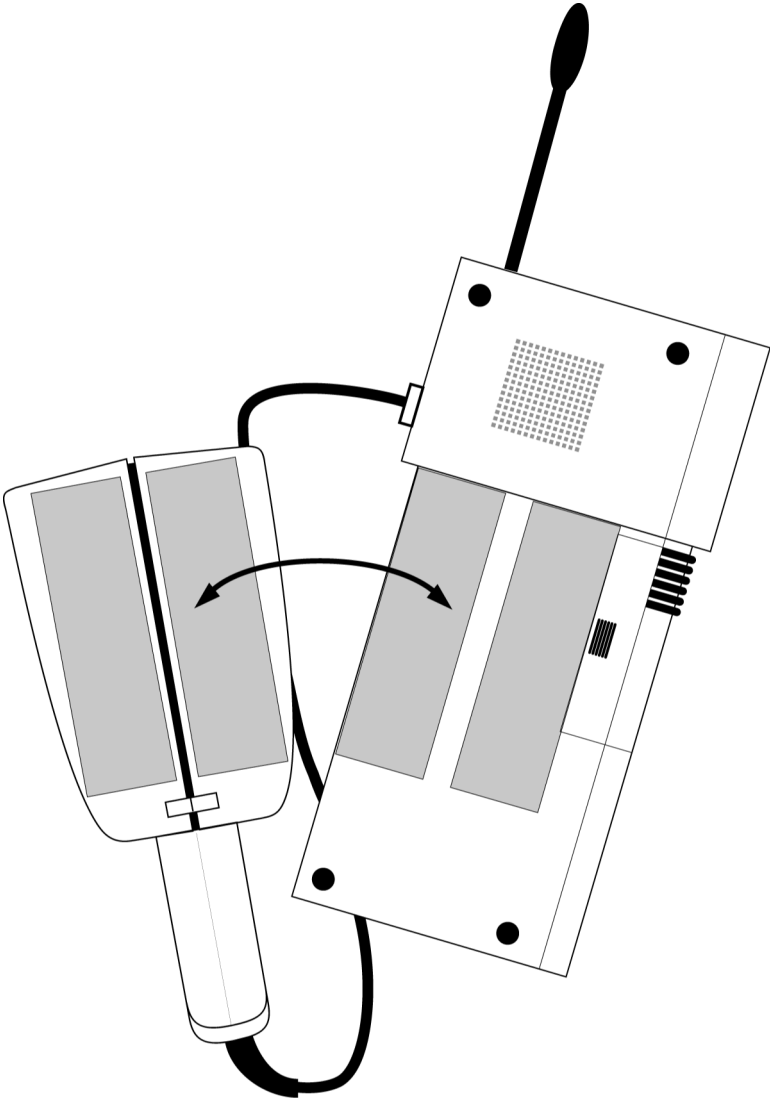

RF Terminal Piggyback configuration

How to scan a bar code

The RF Terminal can be used with a variety of scanners – wands, lasers, and CCDs. Which one you choose is dependent upon your application and the quality and density of your bar codes. This section will include information on different scanners as well as how to use each one.

Wand Scanners

The RF Terminal can be used with the F57 Switch Wand. Scanning with a wand is like drawing a line with a pencil - hold the wand as you would a pencil, about 30 degrees from perpendicular. Squeeze the wide black rubber band (there should now be red light coming from the end of the wand) and “draw” a line through the bar code, starting about ¼” before the bar code and making sure you end at least ¼” past the end of the bar code. You do not have to press hard – a light touch is fine and scanning quickly is preferred to scanning slowly. The key to wand scanning is to make sure you stay on the bar code the whole way though.

Laser and CCD Scanners

If you are using a laser or CCD scanner, technique is not as critical. The scanners are “point-and-shoot”; you can’t miss. Upon triggering the beam, the laser and CCD scans the bar code multiple times (36 scans per second) until it has a good read, at which point it automatically shuts off. These scanners are more expensive, but virtually foolproof. They read from a distance, so they are much more convenient for distance shelf scanning or scanning in tight spots. Different laser scanners have different distance capabilities. **Table M-1** shows the comparison of all the laser and CCD scanners available from Worth Data.

Scanner	Hi Density Code 39	UPC 100%	40 mil Code 39	Paper 100 mil Code39	Retro-Reflective 100 mil Code 39
LI50 CCD	0.5” – 4”	0.5 - 7”	1” – 12”	na	20” – 40”
LZ100 Laser	0 – 6”	0 – 12”	2” – 41”	7” – 41”	28” – 7.5 ft.
LZ200 Laser & Terminal’s Integrated Laser	0.5” – 9”	0 – 17”	3” – 44”	9” – 50”	18” – 9.5 ft.
Symbol 3200 Laser	3.5” – 11”	2” - 22”	10” – 13 ft.	24” – 15 ft.	32” – 28.5 ft.

Table M-1. Scanner Comparison Chart

6 mil = high density
40 mil = low density
100 mil = very low density (with paper and retro-reflective label stock)

To scan a bar code using your laser or CCD scanner, (whether it be a handheld or integrated)

1. put your RF Terminal in One-Way mode with the host computer program not running; or even unplug the serial cable,
2. point the laser scanner at the bar code at about 6" away.
3. Pull the trigger (or push the button on an integrated model) and line up the beam on the bar code. If you don't get a read, vary the distance of the scanner from the bar code by pulling up or moving down. Just as with the wand, the idea is to scan through the center of the bar code.

Laser Options

Several options are applicable to all laser and CCD Scanners that are used with the RF Terminal. These options are: 1) Longer timeout on the laser reading, and 2) Double decode required.

Longer Laser Reading: A temporary solution to problem bar codes is sometimes to increase the length of the time the scanner attempts to read, from the default 2-second beam to a 4-second beam. To select the 4-second beam:

Scan **Start Setup**
Scan **Laser Options**
Scan **3** to select the 4-second beam
Scan **End Setup**

To return to the default 2-second beam, scan 0.

Double Decode: The default setting for the RF Terminal is one successful decode results in a "good read". If you are getting incorrect reads, (due to defective bar codes), a temporary solution is to turn on make the RF Terminal perform two straight identical decodes before beeping, outputting data, and completing a "good read" read.

To activate the double decode:

Scan **Start Setup**
Scan **Laser Options**
Scan **1** to select double decode
Scan **End Setup**

To return to the single decode beam, scan 0.

There are two **Setup Options** that are only apply to the Integrated RF Terminal and the LZ200 laser scanner (they both use the same model of scan engine). The two options are:

- 1) “**Aiming Laser Dot**” for a predetermined time before the laser beam expands into a “line” for reading. The RF Terminal requires a no charge feature to be added to it before shipping for the Aiming Dot to be used.
- 2) “**Difficult Code 39 Reading**” for reading Vehicle Identification Numbers (VIN) through the automobile windshield

Aiming Laser Dot:

(Requires Special Modification on the RF Terminal at Factory)

Sometimes it is difficult to see the laser beam and know you are on the bar code, especially if you are attempting to read outdoors in direct sunlight. The laser can be outputted as a brighter dot for a few seconds, allowing the user to place the dot in the middle of the bar code; then the laser beam starts sweeping for the read. As shipped, the laser beam never forms an aiming dot, but you can program a number of seconds that you wish the aiming dot to appear before the sweeping beam by scanning the following:

From the Keypad, go to **RF Terminal Setup**. Choose “**Other**”. Press Enter repeatedly until you get to the parameter labeled “**AIMING DOT**”. The default is **00**. Enter the time in 1/10s of a second you wish the dot to appear before the laser beam spreads, (i.e. enter 30 for 3 seconds). Remember, this feature is only supported with RFx9082A and higher, the LZ200D scanner, and an RF terminal with factory modifications to support it.

“Difficult Code 39 Reading”:

This setting facilitates reading of difficult Code 39 bar codes such as the Vehicle Identification Number (VIN number) on automobiles, especially reading through a windshield. VIN numbers are long, often weathered, often dirty, and challenging to read.

To enable the more aggressive Code 39 algorithms necessary to read windshield VINs with a LZ200 or with the RF Terminal’s integrated laser:

Scan **Start Setup**

Scan **2 of 5 Code**

Scan **D** for windshield reading

Scan **End Setup**

*To return to the default Code 39 decode algorithms, scan **B** instead of **D**.*

Don’ forget the common sense things you can do to facilitate reading the VIN:

- 1) Be sure the window on the laser scanner is clean.
- 2) Be sure the windshield itself is wiped clean before reading

Appendix N

Using the Scan Stand

Stand mode allows the operator to use an LZ100 laser in “hands free” mode while attached to an RF Terminal. This is useful in shipping applications or any application where the operator requires both hands to perform their function.

Stand Mode is actually a fast cycling laser looking for a bar code (many transitions between black and white). The user scans the bar code on the Stand to activate it. A scan of the same bar code while in "Stand Mode" will deactivate it. The "Stand Mode" on the RF Terminal only supports the external LZ100 Scanner, not the internal scanner and not the LZ200 Scanner. When the scanner detects a suspect bar code, the beam spreads wider and stays on for 2 1/2 second or until a bar code is successfully read. If successfully read, the scanner turns off until the next prompt. If no read occurred, it resumes the cycling looking for a prospective bar code.

When in Stand Mode, if a key is pressed, we assume the user wants to key data instead of scan data, so the scanner is turned off; at this point the scanner can be used if triggered. Once the data entry is finished and transmitted and the next prompt is received from the host program requesting either 1) scanner only input, or 2) scanner/keyboard input; the "Stand Mode" operation is resumed.

The Stand itself is available in two models, one with a weighted base (if you need to move the stand from site to site) or a gooseneck-only model that must be permanently mounted to a surface.

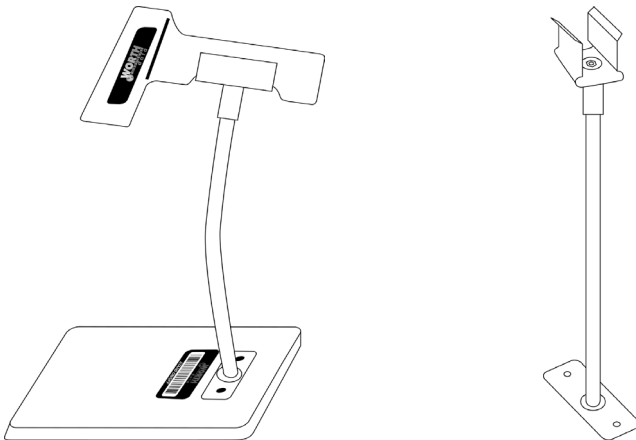

Appendix O

Optional Features

The following are the features available for the RF Terminal:

Item #	Description
F10	5V/110V Power Supply
F11	5V/220V Euro/South American Power Supply
F14	5V/220V UK Power Supply
F13	5V/240V Australian/New Zealand Power Supply
F34	RS-232 Null Modem 8 Pin Modular to 25Pin Female
F36	RS-232 Straight 8 Pin Modular to 9 Pin Female
F44	422 Multi-drop "T" Cable
F38	RF Terminal Cloning Cable
T15	Voice Cloning Cable
T12	Headphone for Version 9
T12	Microphone for Version 9
T24	Piggyback Cable for LZ100 or LZ200
B10	Rubber Boot for LZxx Laser
B11	Rubber Boot for RF Terminal
F40	RF Terminal Carrying Case
T46	Holster for RF Terminal using Rubber Boot (B11)
T47	Piggyback Laser RF Terminal Carrying Case
T48	Integrated Laser RF Terminal Carrying Case
T49	Integrated Laser RF Terminal Belt Holster
F88	Belt Holster for tethered Laser Scanner Gun
H11	Laser Holder for LZxx with or without B10 rubber boot
F57	Wand - Switch Scanner, Med Resolution Visible Light
LZ100	Worth Data Laser Scanner
LZ200	Worth Data Laser Scanner
3200ER	Symbol Long Range Laser Scanner
LI50	Long Range CCD Scanner

CCD Scanners

LI50 Linear Imager Scanner

This CCD scanner reads typical UPC codes from a 0.5" to 7" distance. It acts just like a laser scanner, except the beam is fuzzier than the lasers sharp line across the bar code. The cable (rated for 1,000,000 bends). The warranty is 2 years.

Laser Scanners

The LT7x model RF Terminal is available with an integrated laser scanner for one-handed scanning. This laser uses the Symbol 1200HP Scan Engine with a lifetime warranty on the scan element. We also offer cabled laser scanners (the **LZ100**, **LZ200** and **Symbol 3200ER**) as an add-on, plugging directly into the **SCANNER** port of the RF Terminal.

In addition, we offer the RF Terminal "piggybacked" on a laser scanner. This option uses the T24 cable to attach the RF Terminal to the top of the laser. A one-piece carrying case, the T47 is available for the RF Terminal in this "piggyback" configuration.

The RF Terminal is shipped with the decode light on the laser scanner deactivated so that the RF Terminal can operate interchangeably with a wand or laser. If you want to restrict the RF Terminal's operation to a laser scanner only with the decode light *activated*, simply move the jumper on the inside of the RF Terminal from its setting of *Wand* to *Laser*. See **Appendix A; Frequency and Jumper Changes**, for instructions on how to get inside of the RF Terminal. The Laser jumper is located immediately above the EPROM. Move the jumper to the "L" side and put the RF Terminal back together again.

LZ100 Laser Scanner

This laser scanner uses the Symbol 1200WA Scan Engine with a lifetime warranty on the scan element. The 10 ft. cable is durability rated for 1,000,000 bends. It reads all densities of bar codes down to a 3 mil narrow bar and reads a typical UPC code at about 12". The warranty on the LZ100 is 2 years.

LZ200 Laser Scanner

This laser scanner is the equivalent of the lasers used in the integrated models of the RF Terminal. The LZ200 uses the Symbol 1200HP Scan Engine with a lifetime warranty on the scan element. The LZ200 is the laser scanner of choice if you want to use the RF Terminal in the Piggyback configuration. It can read a 10 mil bar code at 17", a 40 mil bar code at 44 " ft., and a reflective 100 mil bar code at 9.5 ft. It can read high density code down to a 3 mil narrow bar width.

This scanner supports the aiming dot mode, useful for difficult aiming and scanning in bright sunlight.

Durability features include a cable tested to withstand 1,000,000 bends of operation, as well as a scan engine tested to withstand 2000 G's of force. It is an extremely rugged product, made to withstand harsh treatment including repeated drops.

Symbol 3200ER Scanner

This laser is a long-range laser (it reads a 100 mil reflective bar code from up to 35 ft.), but it also reads normal codes. This makes it ideal for reading shelves so high you can't even reach them, (i.e. a forklift operator can scan the shelves without getting up); but it can still read desktop bar codes at close range. It actually has two lasers built-in; one for close up reading, and one for distance reading. It has a two position trigger; the first position stop is an aiming spot, the second position stop triggers the beam. Warranty is 1 year.

Laser Accessories

B10 Rubber Laser Boot

The **B10 Rubber Laser Boot** fits both the LZ100 and LZ200 laser scanners, and the F86 Laser-like CCD scanner. The durable rubber cover was designed to substantially decrease the chance of damaging a laser or CCD scanner if dropped.

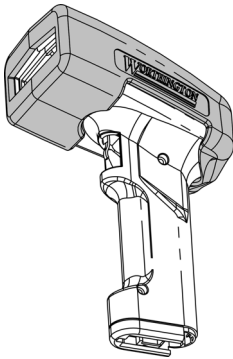

Install the **B10 Rubber Laser Boot** by placing the boot on the windowed end of the laser first, then pulling the boot toward the back of the Laser scanner. The **H11 Laser Holder** can accommodate the laser with or without the rubber boot.

H11 Laser Holder

The H11 Laser Holder is for the LZ100 and LZ200 laser scanners as well as the F86 Laser-like CCD scanner. The holder comes with a removable insert to allow the holder to be used with Lasers or CCDs using the B10 Rubber Laser Boot. The H11 Laser Holder can be mounted vertically (wall) or horizontally (table top). Double-sided tape is included to use for mounting, or you can use wood or metal screws (not provided) to mount the holder. If you are not using the B10 rubber boot, do not remove the Laser Holder insert. If you are using the rubber boot, remove the screw located on the back of the Laser Holder and remove the insert. The holder is now large enough to accommodate the laser scanner with the rubber boot.

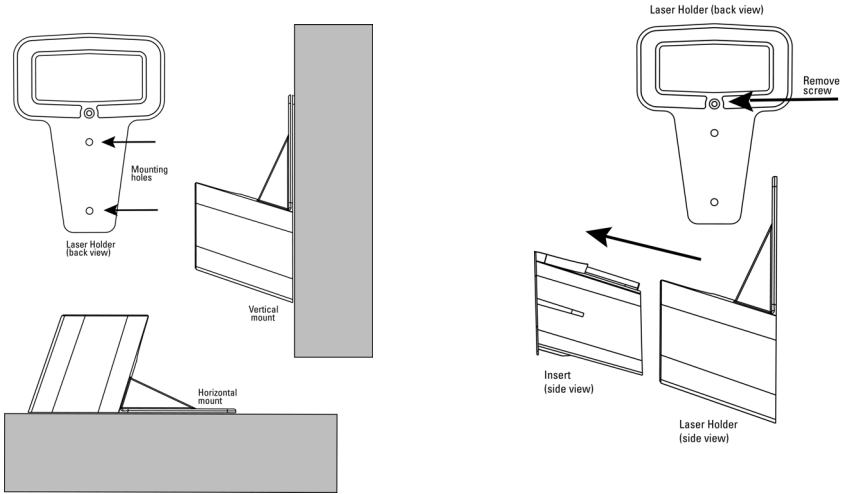

RF Terminal Cases and Holsters

The RF Terminal has a variety of carrying cases and holsters available for use, depending upon the configuration and function of your RF Terminal. Choosing the correct carrying case or holster can increase productivity by making the RF Terminal more accessible and portable.

The RF Terminal can use the following carrying cases and holsters:

F41 Leather RF Terminal Carrying Case



The F40 Leather Carrying Case features either a shoulder strap or belt loop attachment, as well as a convenient holster-style wand holder. The RF Terminal is worn upside down to make it easier for the operator to simply lift the RF Terminal up and view the display and keypad

in the correct orientation. The case has openings for all cable and scanner attachments, making it unnecessary to remove the case for uploading. This case has open access to the RF Terminal keypad but is also available with a clear plastic keypad window to protect the RF Terminal keypad from the elements.



T49 Holster for RF Terminal

The T49 RF Terminal holster is worn on a belt and provides a convenient way to store and carry the RF Terminal during use. The holster can accommodate all models of the RF Terminal without the B11 rubber boot - including the LT integrated models. For RF Terminals using the B11 boot, see the T46 Holster shown below.

T47 Piggyback Terminal Carrying Case

The T47 Piggyback case allows you to cover a RF Terminal and laser mounted in the piggyback configuration. The case protects the laser and RF Terminal and makes the unit easier for the operator to handle. See **Appendix K** for details on how to connect a RF Terminal and laser in the piggyback configuration.



Rubber Boot for RF Terminal

The B11 and B12 Rubber Boot are shipped standard with every LT7x and T7x RF Terminal. They are rugged, protective rubber boots intended to protect the RF Terminal in the most hostile environments. The B11 is included with every LT7x RF Terminal. See below for details on installing the Rubber Boot.



Installing the B11 Rubber Boot

To insert the RF Terminal into the Rubber Boot, start with the laser end of the Terminal first and push the Terminal as far as it will go into the end of the Boot. Make sure that the opening at the end of the boot lines up correctly and fits snugly over the laser window on the Terminal. Now pull the bottom of the boot up and over the bottom of the RF Terminal. To remove the boot, pull the boot off of the bottom of the Terminal, and pull the Terminal out of the boot.



Case for Booted RF Terminals

There are carrying cases available for all models of the RF Terminal that will fit over the rubber boot, providing even more protection against the elements. The case has a vinyl window covering the keypad and includes a shoulder strap as well.

T46 Holster for LT model RF Terminal with Rubber Boot

The T46 holster was designed with ample room in order to accommodate the RF Terminal while encased in the Rubber Boots. The holster is worn on the belt and gives the operator a convenient place to store and carry their RF Terminal during use.



Appendix P

ASCII Code Equivalent Table

The 128 ASCII codes, their 3-digit decimal equivalents and 2-digit hex equivalents are detailed in the below table.

char	hex	3 digit ASCII	char	hex	3 digit ASCII	char	hex	3 digit ASCII	char	hex	3 digit ASCII
NUL	00	000	SP	20	032	@	40	064	'	60	096
SOH	01	001	!	21	033	A	41	065	a	61	097
STX	02	002	"	22	034	B	42	066	b	62	098
ETX	03	003	#	23	035	C	43	067	c	63	099
EOT	04	004	\$	24	036	D	44	068	d	64	100
ENQ	05	005	%	25	037	E	45	069	e	65	101
ACK	06	006	&	26	038	F	46	070	f	66	102
BEL	07	007	'	27	039	G	47	071	g	67	103
BS	08	008	(28	040	H	48	072	h	68	104
HT	09	009)	29	041	I	49	073	i	69	105
LF	0A	010	*	2A	042	J	4A	074	j	6A	106
VT	0B	011	+	2B	043	K	4B	075	k	6B	107
FF	0C	012	,	2C	044	L	4C	076	l	6C	108
CR	0D	013	-	2D	045	M	4D	077	m	6D	109
SO	0E	014	.	2E	046	N	4E	078	n	6E	110
SI	0F	015	/	2F	047	O	4F	079	o	6F	111
DLE	10	016	0	30	048	P	50	080	p	70	112
DC1	11	017	1	31	049	Q	51	081	q	71	113
DC2	12	018	2	32	050	R	52	082	r	72	114
DC3	13	019	3	33	051	S	53	083	s	73	115
DC4	14	020	4	34	052	T	54	084	t	74	116
NAK	15	021	5	35	053	U	55	085	u	75	117
SYN	16	022	6	36	054	V	56	086	v	76	118
ETB	17	023	7	37	055	W	57	087	w	77	119
CAN	18	024	8	38	056	X	58	088	x	78	120
EM	19	025	9	39	057	Y	59	089	y	79	121
SUB	1A	026	:	3A	058	Z	5A	090	z	7A	122
ESC	1B	027	;	3B	059	[5B	091	{	7B	123
FS	1C	028	<	3C	060	\	5C	092		7C	124
GS	1D	029	=	3D	061]	5D	093	}	7D	125
RS	1E	030	>	3E	062	^	5E	094	~	7E	126
US	1F	031	?	3F	063	_	5F	095	DEL	7F	127

Full ASCII Equivalent Table

Index

- 1**
 - 1 second voice messages 7-2
 - 1/2 second voice messages 7-2
- 2**
 - 2 of 5 Code 2-17
 - default length setting 2-18
 - enabling check digit 2-17
 - susceptible to mis-reads 2-18
 - 2 of 5 Codes
 - reading variable length bar codes 2-18
 - 2 of 5 Length 2-18
 - 2 second voice messages 7-2
- 4**
 - 4 digit year option 2-23
 - 4 second laser beam 2-25
 - 422 Cable pin-outs B-4, C-2
 - 422 jumpers A-3, B-7
- 5**
 - 5v power supply needed for Site Testing 4-2
- 6**
 - 6 beeps on power up 8-7
 - 6 line display
 - compatible Base version 6-5
 - 6 line display setup 2-11
- 8**
 - 80 frequencies 2-31
- A**
 - AA batteries 1-4
 - AA Batteries
 - changing 1-6
 - Accumulate Mode E-4
 - numeric barpad table E-4
 - ActiveX programming 6-12
 - Addressing a Terminal not SIGNed ON
 - base to host programming 6-8
 - Advanced Features/Functions for Code 39 E-2
 - AIAG E-1
 - aiming dot M-3
 - aiming dot enabling M-3
 - Alkaline rechargeables 1-4, A-5
 - ANSI information for Code 39 E-1
 - Area of coverage 4-5
 - Arrow Keys Only 2-10
 - ASCII 19 and ASCII 17
 - substituting with ASCII 20 and ASCII 16 for XON/XOFF sensitive systems 2-29
 - ASCII 22
 - Using to SIGN ON 6 line display terminal 6-8
 - ASCII Code Equivalent Table P-1
 - Assigning Error Messages 7-5
 - Australia / New Zealand frequencies 2-6
 - Automobile ID reading M-3
 - Automobile windshield reading M-3
 - AUX jack 7-7
 - average transaction rates 4-7
 - Avoiding incorrect setup with laser 2-3
 - Avoiding substitutions in scanning 2-25
- B**
 - B10 Rubber Laser Boot O-3
 - B11 Rubber Boot
 - installing O-6
 - B11 Rubber Boot for Integrated Laser RF Terminal O-6
 - Backlight Display 2-11
 - setting the duration 2-11
 - using F2 to turn on 2-11
 - Backlight Duration 2-11
 - backwards compatibility for handling illegal statements 6-4
 - Bank settings 2-31
 - Bar code data length checking 2-19
 - Bar Code ID's 2-16
 - Bar Code Menu Only setup parameters 2-1
 - bar code symbol 2-4
 - Bar Code Type identification 2-16
 - Bar Codes
 - Accumulate Mode E-4
 - character substitution 2-22
 - default settings 2-2
 - ID character prefix 2-16
 - preambles and postambles 2-16
 - trimming characters 2-20
 - using Postamble to add terminator character 2-20
 - Base and relay blink "frequency" on power up 1-4
 - Base changes from host 2-32
 - Base is jumpered for programming A-2
 - Base jumper settings A-2
 - Base Listening To:
 - Base Station setup 2-30
 - Base Reinitialized 8-3
 - Base Reinitialized message 6-10, 8-3
 - Base Shut Down 6-9, 8-3
 - Base Station & Relay Firmware upgrades D-1
 - Base Station and Relay cover removal A-1
 - Base Station failures 5-3
 - Base station frequency 1-4
 - Base station handshaking 5-1
 - Base Station Initialized Message 6-10
 - Base Station installation 1-3
 - Base Station location 4-2
 - Base Station Setup 2-27
 - Base Listening to: 2-30
 - Baud Rate 2-29
 - Data Bits 2-30
 - Frequency Bank 2-31
 - Parity 2-30
 - requires jumper change 2-27

Security Code	2-30	using the bar coded setup menu.....	2-2
setting jumper for programming	A-2	Changing Relay setup from host.....	2-32
Stop Bits	2-30	Changing the AA batteries on the	
Xon/Xoff Sensitive.....	2-29	RF Terminal	1-6
Base Station Setup Parameters.....	2-29	Changing the Base Station parameters	
Base Station Setup using the RF Terminal	2-28	from the Host	2-32
Base Station Shut Down to Host Logic.....	8-3	Changing the default voice messages	7-5
Base Station to Host Pin-outs	C-1	Changing the frequency on a Base or	
Base Station to Host Programming Formats.....	6-6	Relay	A-3, B-6
Base to host programming		Changing the RF Terminal frequency	2-5
addressing a terminal not signed on	6-8	Changing the RF Terminal ID	2-5
Base Station Initialized message.....	6-10	Changing the RF Terminals automatic shut-off	
Illegal Commands.....	6-9	time.....	2-24
Sequence Error Message	6-9	Changing the Speaker Volume	7-6
Serial Reply	6-7	Changing the voice message partitions.....	7-2
SIGN ON.....	6-7	Character codes	
SIGN OUT	6-8	reassigning	2-22
Basic architecture of host-terminal dialog	6-1	Characters.....	2-22
Basic command format.....	6-1	Check Character	
Basic RF System communications.....	3-1	Code 39	E-2
Battery conservation technique.....	3-3	Check digits / Checksums	
Battery Functions	1-4	and Accumulate Mode.....	E-4
Battery Life indicator	1-6	Check Digits / Checksums	
battery recharging circuitry.....	1-5	Code 128	H-1
Battery Status indicator	2-22	Code 39	E-2
Baud Rate		Code 93	F-1
Base Station setup	2-29	Interleaved 2 of 5	I-1
Baud Rate for serial printer	2-26	MSI / Plessey	K-1
Beep Tone.....	2-22	UPC/EAN	J-3
Beeping		Check digits/checksums.....	H-2
and Accumulate Mode	E-4	Checking frequency for Site Test	4-2
changing the tone or pitch	2-22	circuit board diagram	A-1
during setup configuration	2-2	Clearing lines on a 6 line display.....	6-2
Before you begin programming	5-1	Clearing lines on terminal	
BEGIN key		4 line vs. 6 line display	6-5
transmitting ASCII 23 to host	6-11	Clearing lines on terminal screen.....	6-2
Belden 1227A1 wire for 422 cables.....	B-4, C-2	Clearing terminal screen	6-2
Blocking unauthorized listening	2-9	cloning Terminal setup	
Body of message command.....	6-1	to other terminals	7-5
bright light problems		Cloning voice messages.....	7-5
aiming dot.....	M-3	cables for	7-5
Buffer Reinitialized.....	8-3	Cloning Voice Messages from RF Terminal to RF	
		Terminal	7-5
C		CLSI format for Codabar.....	2-17
C21 Cameo Printer Cable.....	C-3	CLSI format of Codabar	2-17
Cable pin-outs.....	C-1	Codabar	2-17
Cables		CLSI format	2-17
for relays.....	B-4, C-2	Start/Stop transmission	G-1
needed for voice message cloning.....	7-5	transmitting start and stop characters.....	2-17
types.....	1-3	Codabar Specifications	G-1
Cables for Zebra Cameo Printer.....	C-3	Code 128	2-16
Cameo Printer.....	6-31	Code 128 Specifications	H-1
Cameo printer enabled.....	1-8	Code 128 subsets.....	H-1
Cameo Printer Pin-outs.....	C-3	Code 3 of 9	
Caps Lock ON		setting up.....	2-14
Code 39 setup parameter	2-14	Code 39	
Case for Booted Integrated Laser RF Terminal O-6		about Accumulate mode	E-4
CCD pin-outs.....	C-3	enabling the Mod 43 check character	2-14
Change Batteries.....	8-3	transmitting start and stop characters	2-14
CHANGE BATTERIES.....	1-6	using Caps Lock ON	2-14
Changing ASCII characters used to accommodate		Code 39 Advanced Features/Functions	E-2
XON/XOFF	6-10	Code 39 Specifications	E-1
Changing Base setup from host.....	2-32	Code 93 Specifications	F-1
Changing character output	2-22	Code 93:	2-19
Changing Display mode from 6 line to 4 line ..	2-10	Collision transmission detection.....	4-7
Changing more than one setup parameter at a time		Com port communication problems	2-33, 8-5
		Com port problems on host.....	8-6

Command format from host to terminal	6-1	Displaying the year in a 2 digit or 4 digit format .2-	23
Command section of a programming message ..	6-2	Double Decode	2-25
Communication Problems	8-5	double decode option.....	M-2
Components		Double-scan checking.....	2-25, M-3
included with your RF system	1-1	DOWN ARROW key	
components of a basic RF system.....	3-1	transmitting ASCII 29 to host.....	6-11
Configuring 2 of 5 to look for fixed length		Downloading firmware from your computer to the	
data only	2-18	terminal	D-2
Configuring the Base station.....	1-3		
Connecting a Relay Station.....	B-1	E	
Connecting the Base Station to a serial port	1-2	Earphone volume	<i>See</i> Speaker volume
Conserving batteries.....	3-3	changing.....	7-6
Conserving power		EDI	
by turning off speaker with earphone	7-7	UCC -128 bar code.....	H-2
Contention between terminals.....	4-7	Enabling 2 of 5 check digit.....	2-17
Contention problems	4-7	Enabling transmission of NSC character.....	2-15
Control Keys for Possible Programming	6-11	Enabling UPC/EAN check digits	2-15
Controlling terminals from a		Encore Printer	6-31
remote computer	6-21	Encore printer enabled.....	1-8
Correct Routing for Wiring.....	B-2	END key	
Cover removal on Base or Relay	A-1	transmitting ASCII 24 to host.....	6-11
Coverage	4-5	End of Cloning Hit Any Key.....	7-6
creating programs for the RF System	6-1	End Setup	
crimper needed.....	B-5	scanning to exit Setup mode.....	2-2
		ENTER key	
D		eliminating for Arrow Keys	2-10
Data Bits		Entering a Security Code on an RF Terminal.....	2-9
Base Station setup	2-30	EPROM changes.....	D-1
Data Bits setting for serial printer	2-26	Eprom version identification	1-7
Data Cloning Cable #F38.....	7-5	Eprom versions	
Data Received Was prompt.....	3-4	Australia/New Zealand.....	2-6
DATA XMIT ERROR	7-6	Korean.....	2-7
Date and Time Setting.....	2-23	US/Canada/Mexico.....	2-6
Date Format.....	2-23	Error messages	
Date set.....	2-23	Base Reinitialized	8-3
DB9 Straight Cable pin-outs.....	C-1	voice messages	7-5
dd/mm/yy	2-23	Establishing communication with a Relay	4-4
Dealing with radio traffic contention.....	4-7	European date format.....	2-23
Default frequency bank	2-8	European frequencies	2-7
Default settings		Evaluating your areas range	3-5
returning RF Terminal to	2-1	examples	
RF Terminal	2-1	command statements	6-4
Default voice message partitions	7-2	valid commands from host to terminal.....	6-2
Default Voice Messages	7-5	Exiting One-Way mode	3-5
Default voice messages and numbers	7-5	Extension cables on base station	1-3
delays due to radio signal contention.....	4-7	extra characters at beginning or end of data	8-7
Delays in host response.....	3-3		
Delete key		F	
using	1-4	F1 as "escape" key.....	1-8
deleting display data.....	1-4	F1 to exit modes	1-8
Detecting low batteries on RF Terminal.....	1-6	F2 key	
Determining coverage areas for Base Stations and		to turn on Backlight Display.....	2-11
Relays.....	4-5	F34 DB25 Null Modem Cable Pin-outs	C-1
determining the frequency of a base or relay....	A-3	F36 DB9 Straight Cable Pin-outs	C-1
Determining the frequency on a Base/Relay	1-4	factors to consider before you	
determining the number of terminals possible per		begin programming.....	5-1
Base	4-7	Failure Planning.....	5-2
Determining when the terminal checks the Base.....	3-3	Finishing base configuration	2-31
Dialog architecture.....	6-1	Firmware revision	
difficult Code 39 codes	M-2	how to find our what yours is	1-7
Difficult Code 39 Reading	M-3	Firmware Upgrades	D-1
Display		Fixing substitution - laser read	M-3
Backlight Setup.....	2-11	Forcing "shifted" cursor entry	6-3
Display of Year	2-23	Forgetting your Security Code.....	2-9
displaying date and time on terminal.....	6-2		
displaying the date during operation.....	2-23		

French frequencies	2-7
Frequencies	
Australia/New Zealand	2-6
Korean	2-7
US/ Canada/ Mexico	2-6
Frequency	
adding additional Base Stations	4-8
How to find out what your is on	
RF Terminal	1-8
Frequency and Jumper Changes	A-1
Frequency bank	
Relays only on 0	2-31
Frequency Bank	2-8
Base Station setup	2-31
Frequency Changes	A-3
Frequency of RF Terminal	
default	2-5
Full ASCII Extension to Code 39	E-3
Function Code 1 transmission	H-1
Function keys	6-11

G

German frequencies	2-7
Getting into Site Test Mode	4-2
Going back one screen using F1 key	1-8
Going directly to application on	
power-up	2-11, 2-12
guidelines for evaluating Site Test	4-3

H

H11 Laser Holder	0-4
hands free laser scanning	N-1
Hardware changes on the RF Terminal	A-4
Hardware Failures	5-2
Headphone	7-6
Host application	
slowing down system	8-6
Host computer slowing down RF System	8-6
Host Logic Error	6-9, 8-3
Host programming base setup changes	2-32
Host programming guidelines	6-1
Host programming Relay setup changes	2-32
Host Response Delay	2-13
using to cut down radio traffic	3-3
Host to Terminal Programming	6-1
Hostless demo using One-Way mode	3-4
How many terminals per base?	4-7
How Relay Stations work	See
How Site Testing works	3-5
How the One-Way RF System works	3-4
How the Two-Way RF System works	3-1
How to change the batteries	1-6
How to control the RF Terminal from the host	6-1
How to determine frequency on Base or Relay	1-4
How to determine number of	
terminals per Base	4-8
How to get in and out of modes on	
RF Terminal	1-8
How to get into One-Way mode	3-4
how to open base or relay case	A-1
How to reach Worthington Data Solutions	8-9
How to record voice messages	7-4
How to replace the EPROM	D-2
How to scan a bar code	M-1

I

I can't communicate at all	8-5
ID assignment for Relay	A-3, B-6
ID's for bar code type	2-16
Identifying the type of bar code read	2-16
If you are <i>not</i> connecting to a PC serial port	1-3
Illegal Command	
Base to host programming	6-9
illegal statements	
how RF Terminal handles	2-26
Improving results from Site Test	4-3
Incorrect reading	M-3
Incorrect Routing for Wiring	B-3
Initializing a Terminal	6-1
Installation	1-1
installing base - not on PC	1-3
installing base on PC serial port	1-3
Installation Summary	1-2
Installing the B11 Rubber Boot	O-6
Installing the R/F Terminal Utilities Software	1-9
Interleaved 2 of 5	
check digit calculation	I-1
data length	2-18, I-1
default settings	2-17
Interleaved 2 of 5 Code Specifications	I-1
intervals	
wake up intervals for terminal	3-3
ISBN bar codes	
transmitting in ISBN format	2-15
ISBN format output	2-15
ISBN Specifications	J-2

J

JP103	A-2
JP103 jumper for Programming	
mode on Base	2-27
JP3 laser decode light jumper	A-4
JP4 battery recharge jumper	A-5
Jumper Changes	A-2
jumpering the Base station for programming	A-2
Jumpers	
RS-422 termination	A-3, B-7

K

key symbol	2-4
Keypad Only setup parameters	2-1
Keypad Setup Menu	
parameter groups	2-4
Korea Eprom versions	2-7
Korean frequencies	2-7

L

Label Code 4 and 5	
enabling reading of	2-18
Language problems during data collection	7-1
Laser Comparison Chart	M-1
Laser decode light	A-4
Laser pin-outs	C-3
Laser Scanner options	M-2
Laser Scanner Options	2-25
Laser scanners	
technique for using Setup Menu	2-3

Laser Scanners	M-1, O-2
protective rubber boot	O-3
Laser Terminal feature	L-1
LCD	
Backlight Setup	2-11
LCD Backlight	
setting the duration	2-11
LCD Backlight Display Mode	2-11
LCD Display Mode	2-10, 6-5
via keypad only	2-1
Leading characters	
trimming using preamble	2-19
Leading digits for UPC/EAN	2-15, J-2
Leading spaces and Accumulate mode	E-4
LEFT ARROW key	
transmitting ASCII 30 to host	6-11
Length restrictions on bar codes	2-19
Link Test	8-5
Link Test from base to host	2-33
Literacy as a data collection problem	7-1
LOADER.EXE program to download	
firmware	D-2
Location of Base and Relay	4-5
Logic Error	8-3
LOGMARS	E-1
Longer Laser reading	M-2
Loose decoding algorithm for Laser scanners	2-17
Low Batteries	8-3
Low Battery message	1-6
LZ100 Laser Scanner	O-2
LZ200 Laser Scanner	O-2

M

magnetic stripe input	6-3
Magstripe input	<i>See</i> Zebra Cameo Printer
data format from Cameo	6-31
maintaining backwards compatibility	2-26
Making terminal beep	6-2
Mapping of voice messages	7-2
Maximizing long range laser	2-25
Menu setup using the keypad	2-3
merchandise marts	2-31
message format for host to terminal	
programming	6-1
Metal walls and RF	4-1
Methods to improve Site Test results	4-3
Microphone	7-4
plugging in to AUX jack	7-4
Min/max length checks	2-21
Min/max length checks in Preamble	2-20
Minimum acceptable results for Site Test	4-3
mm/dd/yy	2-23
Modulus 43 Check Characters	E-2
MSI	
check digits	K-1
default settings	2-18
MSI/Plessey	2-18
MSI/Plessey code specifications	K-1
multi-dropping additional Relays	B-1
Multiple	1-4
Multiple Base stations	
changing frequency	1-4
Multiple terminals on a Base	4-7

N

Network planning	4-4
New installation troubleshooting	8-2
New Zealand frequencies	2-6
NiCad batteries	
checking jumpers when recharging	1-7
NiCad rechargeables	1-4, A-5
Nickel Metal Hydride rechargeable	
batteries	1-4, A-5
NiMH	1-4
NiMH and NiCad batteries	
battery life	1-5, A-5
NSC assignments	J-2
NSC characters	
enabling transmission	2-15
Null modem cable pin-outs (F34)	C-1
Numeric "Barpad"	E-4

O

OFF key	
hitting it twice	5-3
ON/OFF button	1-4
One Way Mode	
getting into	1-8
One-Way mode	
adding postamble for ENTER (CR)	3-5
multiple terminals	3-5
using preamble to transmit Terminal ID	3-5
One-Way Mode	
brief description of	3-1
Opening a Base or Relay	A-1
Opening the RF Terminal to change the speaker	
volume	7-6
Operational Theory	3-1
Operator Errors	5-3
Optional Features	O-1
Organic materials' effect on RF	4-1
Outputting ASCII characters	
in place of actual characters entered	2-22
Outputting data to a serial device	
from terminal	6-2

P

Parity	
Base Station setup	2-30
Parity for RF Terminal	2-26
Parity settings to use serial printer	2-26
Partial data from Base to Relay	4-5
Partial reads on EAN-13	2-15
Partitions	
changing for voice messages	7-2
for voice messages	7-2
Password	2-3
PDF 417 scanners	6-3
Performance Issues	4-1
Performing a Site Test	4-2
PICK requirements	8-6
Piggyback Feature	L-1
Piggyback Laser Installation	L-1
Pin-outs	C-1
Zebra Cameo Printer	C-3
Planning for expansion	5-2
Planning for hardware failures	5-2
Planning for system failures	5-1

Playing a voice message on a terminal	6-2
Playing back a recorded voice message	7-3
Plessey code	K-1
Poor lighting situations	
suggestions for dealing with	7-1
poor read rates when scanning bar codes	8-7
Portable Printer Pin-outs	
Zebra Cameo	C-3
Portable Printers	
Zebra Cameo Printer	6-31
Portable printers supported	
Zebra Cameo/Encore	1-8
portable printing	6-31
Portkey	
using with One-Way mode	3-4
Postamble	2-20
using in One-Way mode to send terminator	3-5
using to check data length in NON PORTABLE mode	2-21
Postambles	
selective trimming	2-21
potentiometer to increase speaker volume	A-5
powering up base station after programming	2-33
Power-up	
6 beeps from terminal	8-7
Preamble	2-19
selective trimming	2-20
using in One-Way mode to send Terminal ID.	3-5
using to check data length	2-20
Prefix for bar code types	2-16
Preparing the Base Station for Setup	2-27
Press Enter When Ready prompt	
during Site Test	4-2
Preventing another Base from listening	2-9
Preventing unauthorized listening on system	2-30
Printer	
setting Parity to match serial printer	2-26
Problems reading Bar Codes	8-7
Problems with a new installation	8-2
Programming	
Base to Host formats	6-6
Programming Commands	
clearing individual lines on terminal screen	6-2
clearing terminal screen	6-2
displaying date and time on terminal	6-2
making terminal beep	6-2
outputting data to a serial device on terminal	6-2
playing a voice message on a terminal	6-2
reinitializing terminals	6-2
sample statements	6-4
Programming for the RF Terminal	6-1
Programming Mode jumper	A-2
Programming voice messages	7-1
Programming Voice Messages	7-3
Protocol setting for serial printer	2-26
Q	
quiet zone	8-8
R	
R/F Serial Pin-outs	C-1
R/F Terminal Firmware Upgrades	D-2
R/F Terminal Menu Functions	
ONE-WAY	1-7
SETUP MODE	1-7
SIGN ON	1-7
SITE TESTING	1-7
radio traffic	
reducing by adding Base station	4-7
Radio traffic contention	4-7
Raising the Base station to increase range	4-2
Range problems	8-6
Reader doesn't beep when reading bar codes	8-7
reading through a windshield	M-3
Reading through a windshield	M-3
rearing in sunlight	
aiming dot	M-3
Re-assigning character codes	2-22
Rechargeable Batteries	
how to order	1-5
Recharging time for batteries	A-5
Recording a voice message using the microphone	7-4
Recording and Playback of Voice Messages	7-3
Recording time allotted for voice messages	7-2
Recovering from hardware failures	5-2
Recv Setup/Voice Please Wait	7-6
Reducing radio traffic	3-3
Re-initializing terminals	6-2
Reinitialization	
of Base Station with Terminal Signed-On	6-10
Relay Cannot be Heard	8-4
Relay Existence	2-8
Relay Existence setup parameter	
how to set for Relays	4-4
Relay ID and Frequency	B-5
Relay n Cannot Be Heard by the Base	B-4, B-7
RELAY n CANNOT BE HEARD	
BY THE BASE	4-5
Relay setup changes from host	2-32
Relay Station failures	B-4, B-7
Relay Station RS422 Pin-outs	B-4, C-2
Relay stations	
cable failures	B-4, B-7
Relay Stations	
connecting	B-1
how they work	4-4
multi-dropping additional	B-1
no serial parameters needed	B-2
troubleshooting unconnected relay	B-4, B-7
using to extend RF range	B-1
Relay test cable	B-5
relay wiring	B-2
Relays	
and Site Testing	2-8
not supported in One-Way mode	2-8
overlapping area with Base	4-5
RS-422 termination	A-3, B-7
replacing the EPROM in a Base or Relay	D-1
Replacing the EPROM in a terminal	D-2
resending prompts after a sign-out	5-3
Reset	2-25
response time is poor	8-5
Response time variables	4-7
Restrictions on bar code data length	2-19
restrictions on using arrow keys to transmit special characters	6-11
Results of Site Test	4-3
retransmission	3-3
Return procedures	8-8
RF link test	2-33
RF System	

Base Station failures	5-3	RF Terminal Setup Menu on keypad	2-3
before you begin programming.....	5-1	RF Terminal Setup Parameters	2-5
creating programs to prompt the terminal.....	6-1	RIGHT ARROW key	
operator errors	5-3	transmitting ASCII 31 to host.....	6-11
planning for expansion	5-2	RMA's	8-8
planning for failures	5-1	Rotary Switch (SW1).....	A-3, B-6
planning for hardware failures	5-2	Routing the Wiring	B-2
Relay station failures.....	B-4, B-7	RS-232 Cable Pin-outs	C-1
using Demo programs to test system	5-2	RS232 problems	8-6
using Voice Prompts	7-1	RS-422 Termination Jumpers.....	A-3
RF System Setup.....	2-1	Rubber Boot for LT7x models	
RF system slow-down.....	4-7	installing	O-6
RF Terminal			
battery functions.....	1-4		
how it finds a Relay	4-4		
installation.....	1-4		
opening screen.....	1-7		
sleep mode and wake up intervals	3-3		
system components	1-1		
RF Terminal "wake up" intervals	2-13		
RF Terminal Cases and Holsters.....	O-5		
RF Terminal Default Settings	2-1		
RF Terminal Diagnostic Menu	D-5		
RF Terminal Frequency	2-5		
RF Terminal ID.....	2-5		
in programing message from host to terminal	6-1		
RF Terminal Problems	8-7		
RF Terminal setup			
using keypad to setup.....	2-3		
using the bar coded setup menu	2-2		
RF Terminal Setup	2-1		
2 of 5 Code	2-17		
2 of 5 Length	2-18		
Arrow Keys Only	2-10		
Baud Rate for serial printer	2-26		
Beep Tone	2-22		
Characters.....	2-22		
Code 3 of 9	2-14		
Data Bits setting for serial printer	2-26		
Date Format.....	2-23		
Display of Year	2-23		
Frequency Bank	2-8		
Host Response Delay	2-13		
Laser Scanner Options	2-25		
LCD Backlight Display Mode	2-11		
LCD Display Mode.....	2-10		
MSI/Plessey	2-18		
Parity for serial printer	2-26		
Preamble.....	2-19		
Protocol setting for serial printer	2-26		
Relay Existance	2-8		
Reset	2-25		
RF Terminal Frequency	2-5		
RF Terminal ID	2-5		
Security Code	2-9		
Set Date	2-23		
Set Time	2-23		
Shut Down Time	2-24		
Skip Opening Screens	2-11		
Speaker / Batteries	2-22		
Stop Bits setting for serial printer	2-26		
Voice Message Partitions.....	2-24		
RF Terminal Setup			
Codabar	2-17		
Code 128	2-16		
Code 93	2-19		
UPC/EAN.....	2-15		
		sample command statements	6-4
		Scanner input only	
		breaking out of	6-3
		scanning through a windshield	M-3
		scanning through windshields	2-17
		SEARCH key	
		transmitting ASCII 11 to host.....	6-11
		Security Code	2-9
		Base Station setup.....	2-30
		setting on Terminal.....	2-9
		Security Codes	
		only visible in Base Station setup.....	2-31
		Selective data trimming	
		by bar code type.....	2-20, 2-21
		Sequence Error	8-3
		Sequence Error Message	6-9
		Base Shut Down after 5 straight sequence errors	
		6-10
		Serial cables	
		"noise" problems.....	4-5
		serial device attachment	6-3
		serial input on Terminal.....	6-3
		Serial output command for terminal.....	6-4
		Serial parameters	
		on Base Station	2-29
		Serial pin-outs.....	C-1
		Serial ports	
		additional needed to add multiple Base stations	
		4-8
		Serial printer setup paramters on terminal	2-26
		Serial Reply	
		Base to host programming	6-7
		Set Date.....	2-23
		Set Time.....	2-23
		Setting the Relay ID	A-3
		Settings for jumpers	A-2
		Setup	
		Backlight Duration	2-11
		Base Station	2-27
		RF Terminal.....	2-5
		Setup Cloning	
		to other terminals	7-5
		Setup Menu	
		"Reset" bar code	2-25
		Baud Rate	2-26
		Data Bits	2-26
		Parity	2-26
		RF Terminal Frequency	2-5
		RF Terminal parameters	2-5
		Stop Bits	2-26
		Terminal ID	2-5

SETUP MODE	
using to program voice messages.....	7-3
Setup or playback voice messages	7-3
Sharing a Base Station with multiple	
Terminals.....	2-13
shelf label printing.....	6-31
Short voice messages	
preferable to use	7-1
Shut Down Time	2-24
Shut Down Time feature	1-4
SIGN ON	
Base to host programming.....	6-7
difference between 4 line and 6 line display..	6-8
for 6 line display terminal	6-5, 6-8
SIGN ON for 6 line display	2-10
SIGN OUT	
Base to host programming.....	6-8
missing the message	5-3
Signing out in mid-transaction	5-3
site map.....	4-2
Site survey	3-5
Site Test Mode	
brief description of	3-1
Site Testing	
frequency changes	4-2
getting into.....	1-8
how it works.....	3-5
using a Site Map to record results	4-2
Site Testing in Progress message	4-3
Six beeps on power-up	8-7
Skip Opening Screens	2-11
Skipping the Mode Menu	1-9
sleep mode for RF Terminal	3-3
Speaker / Batteries.....	2-22
speaker volume.....	A-4
Speaker volume	
changing	7-6
Speeding up data collection by using Voice	
Prompts.....	7-1
splitting your terminals between Base stations..	4-8
Stand mode.....	<i>See</i>
Start Setup	
scanning to enter Setup mode.....	2-2
Start/stop characters	
transmitting for Codabar.....	2-17
transmitting for Code 39	2-14
STATUS key	
reserved for date/time only.....	6-11
using to determine battery life.....	1-6, 2-12, 8-2
Steps for installation	1-2
STK bar code.....	2-16
Stop Bits	
Base Station setup	2-30
Stop Bits for serial printer.....	2-26
Storage Tek bar code	2-16
Storage Tek Tape Label code.....	2-16
substitution errors	M-2
Substitutions	
avoiding with laser scanner	2-3
Substitutions of data	M-3
sunlight problems,	
aiming dot.....	M-3
Support for Zebra printers.....	1-8
Surveying a site	4-1
Symbol 3200ER Scanner.....	O-3
System architecture	6-1

T

T46 Holster for LT model RF Terminal with B11	
Rubber Boot	O-6
T47 Piggyback Terminal Carrying Case	O-6
T49 Holster for RF Terminal	O-5
Tape library bar code	2-16
TCP/IP Terminal Programming.....	6-21
Terminal ID	
how to find out what yours is.....	1-7
use in Two-Way mode.....	3-2
Terminal ID in One Way mode.....	3-5
Terminal keys	
transmitting ASCII values	2-10
Terminal setup	
Security Code.....	2-9
Terminal Setup Cloning	
to other terminals	7-5
Terminating a programming message.....	6-2
Terminator character.....	2-20
Testing Base Station communications.....	2-33, 8-5
Testing communication with a Relay	B-5
Testing the Relay	B-5
Testing the terminal-to-relay link	2-33, 8-5
Thru-put considerations	4-7
Time Set.....	2-23
time stamping in Terminal	6-3
Tips for Using Voice Prompts	7-1
Trailing character trimming	2-21
Transmission Failed.....	2-28
TRANSMISSION FAILED.....	3-3, 3-4
Transmitting Bar Code ID's.....	2-16
Transmitting characters before or after bar code	
data	2-19
Transmitting Codabar start and stop characters ..	2-17
Transmitting EAN-8/UPC-E in	
original formats.....	2-16
Transmitting through walls.....	4-1
Trimming by bar code type	
using bar code ID and postamble.....	2-21
using bar code ID and	
preamble/postamble	2-20
Trimming characters from data.....	2-21
Trimming characters from data.....	2-19
Trimming leading characters	
using Preamble.....	2-19
Trimming trailing characters	
using Postamble	2-20
Troubleshooting	8-1
electrical noise problems with Relays	4-5
wiring problems with Relays	4-5
Troubleshooting new installation.....	8-2
Turning off the speaker	
when using the earphone.....	7-7
Turning on the R/F Terminal	1-4
Turning the speaker off to conserve batteries..	2-22
Two-Way Mode	
brief description of.....	3-1
in depth description of how it works	3-2
Typical coverage.....	4-5

U

UCC 128 Serial Shipping Container bar code ..	H-3
UCC/EAN Code 128	
enabling/disabling	2-16
UCC-128/ EAN-128	H-1

UK Frequencies.....	2-7
UNIX requirements and problems.....	2-33, 8-5
UP ARROW key	
transmitting ASCII 28 to host.....	6-11
UPC 2 and 5-character supplemental codes	J-2
UPC/EAN.....	2-15
about.....	J-1
Check digit.....	J-1
compressed format.....	2-16
default settings.....	2-15
guidelines for use.....	J-2
NSC and check digit.....	2-15
NSC's and check digits.....	2-15
numbering conventions.....	J-2
supplemental codes.....	2-15
UPC-A - adding a country code.....	2-15
UPC-A in 13 digit EAN format.....	2-15
UPC/EAN check digits	
enabling transmission of.....	2-15
UPC/EAN checksum character.....	J-3
UPC/EAN Specifications.....	J-1
UPC/EAN Supplements	
enabling/disabling.....	2-15
UPC-E Checksum Calculation.....	J-4
UPC-E0 and UPC-E1.....	2-15
UPC-E1	
enabling reading of.....	2-17
Upgrading firmware in Base,Relay	
or Terminal.....	D-1
US Date Format.....	2-23
USA / Canada / Mexico frequencies.....	2-6
USA/Canada/Mexico	
EPROM version identification.....	2-6
Using Arrow Keys to transmit characters.....	2-10
Using RFDEMO to troubleshoot radio.....	8-6
Using the bar code RF Terminal Setup Menu ...	2-2
Using the Demo Programs before	
programming.....	5-2
Using the keypad to setup the RF Terminal	2-3
Using the Relay instead of the Base to	
communicate.....	4-4
Using the RF Terminal keypad.....	1-4
Using the Scan Stand.....	N-1
Using Windows RF Terminal	
EPROM Loader.....	D-3
Utilities CD.....	1-9

V

Vehicle ID reading.....	M-3
Version	
9075.....	2-11, 6-5
VIN reading.....	M-3
Voice Cloning Cable #T15.....	7-5
Voice message "command".....	6-2
Voice message mapping.....	7-2
Voice Message Operations.....	7-1
Voice message partitions	
changing.....	7-2
Voice Message Partitions.....	2-24
Voice messages	

cloning from RF Terminal to RF Terminal....	7-5
eaphone only option.....	2-22
error conditions.....	7-5
playback.....	7-3
record error messages for all situations.....	7-2
use a calm voice when recording.....	7-1
varying your tone of voice when recording....	7-2
Voice Messages	
changing the time allotments.....	2-24
short messages are preferable.....	7-1
Voice Operations selection on SETUP Menu.....	7-3
Voice Prompts	
helping to limit mistakes.....	7-1
Volume potentiometer.....	7-6

W

Waiting for Base to Acknowledge.....	8-3
Waiting on Host Prompt.....	8-3
WAITING ON HOST PROMPT.....	3-2
Waiting on Host Prompt".....	8-3
Wand Scanners.....	M-1
Wand vs. keypad entry.....	6-3
Wandering variable data.....	E-4
WDTRI password.....	2-3
What to do with data after a failure.....	5-2
What to do with data after an operator error.....	5-3
Why Use Voice Messages and Prompts?.....	7-1
Windows 95 com port setup.....	8-6
Windows ActiveX programming.....	6-12
Windows RF Loader program.....	D-2
Windows TCP/IP terminal programming.....	6-21
Windows' <i>Terminal</i>	
using with One-Way mode.....	3-4
Windshield Reading.....	M-3
Wrong data.....	M-3

X

Xmit Setup/Voice Please Wait.....	7-6
XON/XOFF	
changing ASCII characters to avoid conflict6-	10
Xon/Xoff Sensitive	
Base Station setup.....	2-29

Y

Year	
2000 compliance.....	2-23
displaying 4 digits.....	2-23
YES/NO entry while scanning.....	6-3

Z

Zebra Cameo Printer.....	6-30, C-3
hardware modification.....	6-31
setup for use with RF Terminal.....	6-30
Zebra Encore Printer.....	6-31
Zebra printer capable.....	1-8